

Max-Planck-Institut für Mathematik Bonn

Homotopy theory of algebras of substitutes and their
localisation

by

Michael Batanin
David White

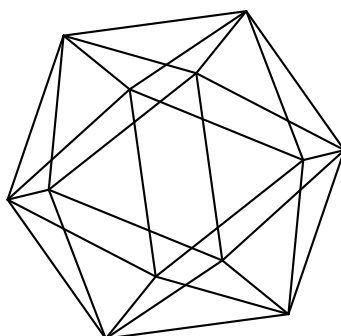

Homotopy theory of algebras of substitutes and their localisation

Michael Batanin
David White

Max-Planck-Institut für Mathematik
Vivatsgasse 7
53111 Bonn
Germany

Department of Mathematics
Macquarie University
Sydney, NSW 2109
Australia

Department of Mathematics and
Computer Science
Denison University
Granville, OH 43023
USA

HOMOTOPY THEORY OF ALGEBRAS OF SUBSTITUTES AND THEIR LOCALISATION

MICHAEL BATANIN AND DAVID WHITE

ABSTRACT. We study the category of algebras of substitutes (also known to be equivalent to the regular patterns of Getzler) equipped with a (semi)model structure lifted from the model structure on the underlying presheaves. We are especially interested in the case when the model structure on presheaves is a Cisinski style localisation with respect to a proper Grothendieck fundamental localiser. For example, for $\mathbb{W} = \mathbb{W}_\infty$ the minimal fundamental localiser, the local objects in such a localisation are locally constant presheaves, and local algebras of substitutes are exactly algebras whose underlying presheaves are locally constant.

We investigate when this localisation has nice properties. We single out a class of such substitutes which we call left localisable and show that the substitutes for n -operads, symmetric, and braided operads are in this class. As an application we develop a homotopy theory of higher braided operads and prove a stabilisation theorem for their \mathbb{W}_k -localisations. This theorem implies, in particular, a generalisation of the Baez-Dolan Stabilisation Hypothesis for higher categories.

CONTENTS

1. Introduction	1
Part 1. Some general homotopy theory	4
2. Semimodel categories	4
2.1. Definition of semimodel category	4
2.2. Transfer of semimodel structures	5
3. Left Bousfield localisations and their liftings	7
4. Beck-Chevalley squares	9
4.1. Beck-Chevalley squares and homotopy Beck-Chevalley squares	9
4.2. Lifting of Quillen equivalences	10
Part 2. Semimodel structures for algebras of substitutes	11
5. Substitutes, convolution and polynomial monads	11
5.1. Substitutes	11
5.2. Convolution through Grothendieck construction	13
6. Substitutes and internal algebra classifiers	16
6.1. Σ -free substitutes and polynomial monads	16
6.2. Internal algebra classifiers	17
6.3. Exact and semiexact squares of polynomial monads	18
7. Unary tame substitutes	19
7.1. Fiberwise disconnected morphisms of polynomial monads	20
7.2. Tame polynomial monads	20

7.3. Unary tame substitutes	22
7.4. Semifree coproduct and convolution	24
8. Transfer theorem	25
8.1. Convolution and Transfer of semimodel structures	25
8.2. Classifier for free algebra extensions	27
8.3. Canonical filtration	30
8.4. End of proof of Transfer Theorem	31
8.5. Beck-Chevalley morphisms of substitutes	32
Part 3. Localisation of algebras of substitutes	33
9. Localisation of presheaf categories	33
9.1. Fundamental localisers	33
9.2. Locally constant presheaves	34
9.3. Local (semi)model structures on presheaves	36
9.4. Truncated homotopy types	39
10. Local (semi)model structures on algebras	40
10.1. Disconnected and constantly disconnected functors and bimodules	40
10.2. Left localisable substitutes	41
10.3. First examples and applications	43
Part 4. Higher braided operads	46
11. n -operads	46
11.1. n -ordinals and quasibijections	46
11.2. n -operads	48
11.3. Symmetrization of n -operads	49
12. Locally constant n -operads	51
12.1. Locally constant n -operads, recollection	51
12.2. Model theoretical refinement	51
13. Localisability of substitutes for operads	53
13.1. Polynomial monad for n -operads	53
13.2. The bimodules $d(NO^{(n)})$ and $d(O^{(n)})$ are constantly disconnected	55
13.3. $(NO^{(n)}, Q_n^{op})$ and $(O^{(n)}, Q_n^{op})$ are unary tame	56
14. Stabilisation of operads and algebras	57
14.1. Stabilisation of higher braided operads	57
14.2. Baez-Dolan stabilisation	59
Bibliography.	61

1. INTRODUCTION

In the paper [BB17] of Batanin and Berger a general approach to the homotopy theory of algebras over polynomial monads was proposed. The category of polynomial monads is equivalent to the category of symmetric Σ -free operads in Set [GK13]. Algebras of such monads include covariant presheaves, monoids, and many types of generalised operads (nonsymmetric, symmetric, cyclic, modular, n -operads, etc.). It makes sense to consider the category of algebras $\text{Alg}_{\mathcal{T}}(\mathbb{V})$ of a polynomial monad \mathcal{T} with values in an arbitrary symmetric monoidal category \mathbb{V} . If \mathbb{V} is equipped with a model structure one can try to invert those morphisms

in $\text{Alg}_{\mathcal{T}}(\mathbb{V})$ which are weak equivalences on underlying collections. This way we obtain the homotopy category of algebras $\mathbb{H}\text{oAlg}_{\mathcal{T}}(\mathbb{V})$.

An important problem is whether we can realise $\mathbb{H}\text{oAlg}_{\mathcal{T}}(\mathbb{V})$ as the homotopy category of a model category. To solve the realisation problem, we can try to transfer the product model structures along the forgetful functor

$$\eta_0^* : \text{Alg}_{\mathcal{T}}(\mathbb{V}) \rightarrow [T_0, \mathbb{V}] \cong \prod_{\text{Ob}(T_0)} \mathbb{V}$$

where T_0 is the discrete category on the objects set (colours) of \mathcal{T} and $[A, \mathbb{V}]$ stands for the category of covariant presheaves on a small category A with values in \mathbb{V} . In this transfer process we define a morphism $f \in \text{Alg}_{\mathcal{T}}(\mathbb{V})$ to be a weak equivalence or fibration provided $\eta_0^*(f)$ is a weak equivalence or fibration in $[T_0, \mathbb{V}]$. In the paper [BB17] some very general model theoretical conditions on \mathbb{V} and combinatorial conditions on \mathcal{T} were found which guarantee that the transfer process, indeed, leads to a model structure on algebras. Furthermore, this model structure on algebras satisfies several additional good properties [BB17] that we will use.

The transfer approach above, though a very useful method, is not, however, the only desirable way to get a model category structure on algebras of a polynomial monads. Any polynomial monad has an underlying category of unary operations $U(\mathcal{T})$. Therefore, we can choose a small subcategory A of this category (which we can assume to have the same set of objects T_0) and consider a morphism of polynomial monads $\eta : \mathcal{A} \rightarrow U(\mathcal{T}) \rightarrow \mathcal{T}$ and, hence, a restriction functor

$$\eta^* : \text{Alg}_{\mathcal{T}}(\mathbb{V}) \rightarrow [A, \mathbb{V}].$$

The category of presheaves $[A, \mathbb{V}]$ can have a model structure of its own and we can try to transfer this model structure to the category of algebras. For example, we can first transfer a model structure from $[T_0, \mathbb{V}]$ to $[A, \mathbb{V}]$. The resulting model category $[A, \mathbb{V}]_{\text{proj}}$ is known as the *projective* model structure. If we transfer the projective model structure along η^* we get exactly the same structure as transferred along η_0^* .

The projective model structure is not the only model structure we can seek to transfer. For example, $[A, \mathbb{V}]$ can have a Reedy model structure. This was considered by Benoit Fresse [Fre12, Part 2, §8.3] in the context of transferred model structures on operads.

In this paper we explore yet another possibility. One can take $[A, \mathbb{V}]_{\text{proj}}$ and take a left Bousfield localisation of it with respect to an appropriate set of morphisms. One can ask then, if this local model structure is transferrable to $\text{Alg}_{\mathcal{T}}(\mathbb{V})$. If it is, the result of the transfer is itself a Bousfield localisation of the category of algebras [BW16].

This question in general does not, probably, admit a satisfactory answer. Though, if we restrict the class of localisations we get some reasonable conditions on the monad \mathcal{P} with a distinguished subcategory of unary operations A . We consider what we call *Cisinski localisations* of the category of presheaves. For this we fix a class \mathbb{W} , of functors between small categories, that satisfies certain conditions. Namely \mathbb{W} must be a proper fundamental localiser in the sense of Grothendieck [Cis06, Mal05]. In this case there is a localisation $[A, \mathbb{V}]_{\text{proj}}^{\mathbb{W}}$ of the category $[A, \mathbb{V}]_{\text{proj}}$ whose local objects are so-called *\mathbb{W} -locally constant presheaves*. For example, if $\mathbb{W} = \mathbb{W}_{\infty}$ is the minimal fundamental localiser [Cis06] then the \mathbb{W}_{∞} locally constant presheaves are exactly those presheaves $X : A \rightarrow \mathbb{V}$ for which $X(f)$ is a weak equivalence for

any morphism f in A [Cis09]. The homotopy category $\mathrm{Ho}[A, \mathbb{V}]_{proj}^{\mathbb{W}\infty}$ is therefore the homotopy category of ∞ -category of representations of the groupoid $\Pi_\infty(A)$ in \mathbb{V} . If a transfer of this localisation to $\mathrm{Alg}_{\mathcal{P}}(\mathbb{V})$ exists, the corresponding homotopy category of algebras can be thought as algebras of \mathcal{P} in which unary operations from A are invertible up to all higher homotopies.

Remark 1.0.1. A different approach to the question of weak inversion of unary operations in case of algebras of one coloured operad was implemented in [BBPTY16a]. The authors construct an explicit operadic version of Dwyer-Kan hammock localisation to settle this question.

Here is the plan of the paper. In Part 1 we provide some general homotopy theoretical facts which we will need in the rest of the paper. To handle Bousfield localisation in sufficient level of generality we need to leave the environment of full model structures and allow ourselves to work in what is known as semimodel category structures. We recall what these are in Section 2. Transferred semimodel structures often exists even when full model structures do not. We recall the main ingredients of the transfer procedure in this section. Even more striking is the fact that semimodel left Bousfield localisation exists without left properness. This is the content of our paper [BW20] but in Section 3 we briefly outline this theory. Section 4 is devoted to the theory of homotopy Beck-Chevalley squares which will be our main tool for the comparison of various localised categories of algebras. To our surprise we did not find in the literature some sufficiently elementary results on how the homotopy Beck-Chevalley property can be used to lift Quillen equivalences. So, we include this discussion in this section.

In Part 2 we come to our main object of study: Σ -free substitutes. Substitutes in general were defined by Day and Street as a common generalisation of lax-monoidal structures and operads [DS03a, DS03b]. They are also known to be equivalent to the regular patterns of Getzler [Get10, BKW18]. Basically they are coloured operads together with a structure of a small category on the set of colours. A Σ -free substitute is a substitute in Set in which the symmetric group action is free. This is exactly the data for a polynomial monad together with a distinguished set of unary operations as we discussed at the beginning of the Introduction. In Section 5 we recall the definition of the Day-Street convolution operation for substitutes, which will play a primary technical role in our paper. Section 6 reminds the reader about the theory of internal algebra classifiers developed through many years in [Bat07, Bat08, BB17, BL17]. And in Section 7 we generalise to Σ -free substitutes the theory of tame polynomial monads developed in [BB17]. Tameness is the main combinatorial criteria used in [BB17] to handle the question of transfer. Here, we generalise it to the notion of *unary tame substitute* to take into consideration the action of unary operations.

Our main observation is that for a unary tame substitute the semifree coproduct (a coproduct of an algebra X with a free algebra on an A -presheaf K) is a natural retract of a certain convolution of the underlying presheaf $\eta^*(X)$ and K . This allows us to deduce good homotopy theoretical properties of the semifree coproduct (and as a consequence good homotopy properties of free algebra extensions) from good properties of the convolution. In Section 8 we use this fact to get a general transfer theorem (Theorem 8.1.7) from model structures on the category of presheaves to semimodel structures on the category of algebras, provided the convolution operation of the substitute is a left Quillen functor of many variables.

The proof of Theorem 8.1.7 follows the same basic plan as the proof of the transfer theorem for tame polynomial monads from [BB17], but also can be considered as a lax-monoidal generalisation of the Schwede-Shiplay proof of the transfer theorem for monoids [SS00].

In Part 3 we apply the Transfer Theorem to the localised category of presheaves. In Section 9 we first construct the model categories of W -locally constant presheaves following the ideas of Cisinski from [Cis09] where such a localisation was constructed for the minimal fundamental localiser W_∞ . We then show in Section 10 that this localisation satisfies the conditions of our Transfer Theorem provided our substitute is unary tame and satisfies one more combinatorial condition. We call such substitutes *left localisable*. At the end of Section 10 we consider several examples of left localisable substitutes. In particular, we show that Cisinski’s model structure for locally constant presheaves can be constructed relatively for any subcategory of A and, therefore, one can “weakly” invert only a subset of morphisms of A in full analogy with the classical categorical localisation. We also consider a monoidal version of Cisinski’s localisation as an example of the application of our methods.

Part 4 is our main application. After reviewing preliminary definitions in Section 11, we solve the relevant realisability problem in Section 12, producing a model structure for locally constant n -operads. We show in Section 13 that substitutes whose algebras are symmetric, braided, or n -operads in the sense of the first author [Bat08] are left localisable. Using this, we describe the category of higher braided operads for every $n \geq 0$ as a localisation of the category of n -operads. For the minimal localiser W_∞ the local objects of this category are exactly the n -operads on which quasibijections of n -ordinals act as weak equivalences. Since the homotopy type of the category of quasibijections is the same as the homotopy type of unordered configuration spaces of points in \mathbb{R}^n these locally constant n -operads play the role of higher braided operads. In Section 14, we use these results to prove a stabilisation theorem for these operads from which the Baez-Dolan stabilisation hypothesis for higher categories is a consequence. This completes the promise we made in [BW15].

Part 1. Some general homotopy theory

In this part, we recall a few definitions and results from abstract homotopy theory, that we will require. We assume the reader is familiar with model categories at the level discussed in [Hir03, Hov99].

2. SEMIMODEL CATEGORIES

In this section we set up our definition of semimodel category and recall the techniques of transferring of semimodel structures along a right adjoint.

2.1. Definition of semimodel category. We begin with the definition of a semi-model category (sometimes written ‘semi-model category’), taken from [Bar10] (and slightly generalizing Spitzweck’s notion of a J -semi model category [Spi01]). We follow the definition with an explanation of what semimodel categories are good for, and how semimodel categories arise. Recall that, for a set of morphisms S , $\text{inj } S$ refers to the class of morphisms having the right lifting property with respect to S .

Definition 2.1.1. A *semimodel structure* on a category \mathbb{M} consists of classes of weak equivalences \mathcal{W} , fibrations \mathcal{F} , and cofibrations \mathcal{Q} satisfying the following axioms:

- M1 The initial object is cofibrant.
- M2 The class \mathcal{W} is closed under the two out of three property.
- M3 \mathcal{W} , \mathcal{F} , \mathcal{Q} are all closed under retracts.
- M4
 - i Cofibrations have the left lifting property with respect to trivial fibrations.
 - ii Trivial cofibrations whose domain is cofibrant have the left lifting property with respect to fibrations.
- M5
 - i Every map in \mathbb{M} can be functorially factored into a cofibration followed by a trivial fibration.
 - ii Every map whose domain is cofibrant can be functorially factored into a trivial cofibration followed by a fibration.
- M6 Fibrations are closed under pullback.

If, in addition, \mathbb{M} is bicomplete, then we call \mathbb{M} a *semimodel category*. \mathbb{M} is said to be *cofibrantly generated* if there are sets of morphisms I and J in \mathbb{M} such that $\text{inj } I$ is the class of trivial fibrations, $\text{inj } J$ is the class of fibrations in \mathbb{M} , the domains of I are small relative to I -cell, and the domains of J are small relative to maps in J -cell whose domain is cofibrant. We will say \mathbb{M} is *combinatorial* if it is cofibrantly generated and locally presentable.

Note that, in a semimodel category \mathbb{M} , the axioms of a full model structure are satisfied on the subcategory of cofibrant objects. Furthermore, \mathbb{M} has a cofibrant replacement functor defined on every object. Consequently, every result about model categories has a semimodel categorical analogue, usually obtained by cofibrantly replacing as needed. This includes the Fundamental Theorem of Model Categories (characterizing morphisms in the homotopy category), left and right Quillen functors, Ken Brown's lemma, path and cylinder objects, the retract argument, the cube lemma, simplicial mapping spaces, Hammock localisation, projective/injective/Reedy semimodel structures, latching and matching objects, cosimplicial and simplicial resolutions, computations of homotopy limits and colimits, and more. We remark that a pair of adjoint functors between semimodel categories is called a Quillen pair if the right adjoint preserves fibrations and trivial fibrations. In practice, a semimodel structure is just as useful as a full model structure.

2.2. Transfer of semimodel structures. Suppose \mathbb{M} is a semimodel category, \mathcal{T} is a monad on \mathbb{M} , U is the forgetful functor from \mathcal{T} -algebras to \mathbb{M} and F is its left adjoint. For the *transferred (semi)model structure* on \mathcal{T} -algebras, we define a morphism f to be a weak equivalence (resp. fibration) if and only if $U(f)$ is a weak equivalence (resp. fibration) in \mathbb{M} . The class of cofibrations is defined by the left lifting property with respect to trivial fibrations. An algebra X is cofibrant provided the unique morphism $F(0) \rightarrow X$ is a cofibration, where 0 is the initial object in \mathbb{M} . A simple adjunction argument shows $F(0)$ is itself cofibrant.

We now recall a condition is required for producing functorial factorisations in the category of \mathcal{T} -algebras. Let I (resp. J) denote the set of generating (trivial) cofibrations of \mathbb{M} . Following [Fre09, Section 12.1.3], we say FI (resp. FJ) *permits the small object argument* if the domains of morphisms in FI (resp. FJ) are small

relative to the class of relative FI -cell complexes (resp. relative FJ -cell complexes with cofibrant domain).

Recall that, for a set of cofibrations \mathcal{K} , the class of *relative \mathcal{K} -cell complexes* is the class of morphisms obtained as transfinite compositions of pushouts of morphisms in \mathcal{K} . When we speak of a *FJ -cell complex with cofibrant domain*, this means we are considering pushouts of \mathcal{T} -algebras of the form

$$(2.2.1) \quad \begin{array}{ccc} F(K) & \xrightarrow{F(f)} & F(L) \\ g \downarrow & & \downarrow \\ X & \xrightarrow{p} & B \end{array}$$

where X is a *cofibrant \mathcal{T} -algebra*, and $f : K \rightarrow L$ is in J . When we speak of a *relative FJ -cell complex with cofibrant domain*, we mean a transfinite composition of morphisms p as above. In particular, each object in the transfinite composition must be cofibrant (because the morphisms $F(f)$ are cofibrations, as we will see in Theorem 2.2.1).

There are several semimodel category existence theorems already in the literature [Fre09, Theorem 12.1.4], [Spi01, Theorem 2], [WY18, Theorem 2.2.2], each producing a slightly different variant of a semimodel structure. Each of these theorems starts with a base model category \mathbb{M} . The following existence theorem starts with a base semimodel category \mathbb{M} , but its proof is exactly like the previous existence theorems.

Theorem 2.2.1. *Let \mathbb{M} be a cofibrantly generated semimodel category, with sets of generating (trivial) cofibrations I and J , such that U preserves filtered colimits. Assume that the sets FI and FJ permit the small object argument, and that relative FJ -cell complexes with cofibrant domain are weak equivalences.*

Then the category of algebras $\text{Alg}_{\mathcal{T}}$ admits a transferred cofibrantly generated semimodel structure with generating (trivial) cofibrations FI and FJ .

Proof. The proof proceeds just like the transfer theorem for model categories [Fre09, Theorem 11.1.13]. The class of weak equivalences is defined as the class of morphisms f such that Uf is a weak equivalence in \mathbb{M} . The class of fibrations is defined as FJ -inj, i.e., morphisms with the right lifting property with respect to FJ . The class of cofibrations is defined as FI -cof, i.e., morphisms with the left lifting property with respect to FI -inj. An adjunction argument tells us FI -inj is exactly the class of trivial fibrations (hence, axiom (M4i) is automatic), and that f is a fibration if and only if $U(f)$ is a fibration. Since J is contained in the cofibrations of \mathbb{M} , a lifting and adjunction argument shows that FJ is contained in the cofibrations of $\text{Alg}_{\mathcal{T}}$, using [Bar10, Lemma 1.7] (it follows that FJ -cell is contained in the cofibrations). Axioms (M1), (M2), (M3), and (M6) are inherited from \mathbb{M} . Axiom (M5i) follows from the small object argument and [Hov99, Lemma 2.1.10]. Axiom (M4ii) follows from (M4i) and (M5ii) just as in [Fre09, Theorem 11.1.13] (adding the requirement that the domain be cofibrant). Lastly, Axiom (M5ii) follows just as in [Fre09, Theorem 11.1.13], via the small object argument in $\text{Alg}_{\mathcal{T}}$. The factorisation is only required for morphisms with cofibrant domain, so the left leg is a relative FJ -cell complex with cofibrant domain, hence a weak equivalence by our assumption (and a cofibration, as we have already observed). The right leg is in FJ -inj, so is a fibration by definition. \square

The conditions of Theorem 2.2.1 have been verified for many categories of algebras over coloured operads [WY18]. For general monads, it can be hard to verify that FJ -cell complexes with cofibrant domain are weak equivalences. Proposition 2.2.2 provides one technique for doing so. The smallness conditions in Theorem 2.2.1 (i.e., permitting the small object argument) are automatically satisfied in locally-presentable settings. However, the result below provides a way to side-step the smallness conditions, and also to learn about when the forgetful functor U preserves cofibrant objects. This result goes back to [Spi01, Theorem 2] (it is the reason for the assumption on TI -cell therein) and [BM03, Corollary 5.2]. It is also included in [Fre09, Theorem 12.1.4] and [WY18, Proposition 6.2.5].

Theorem 2.2.2. *Let \mathbb{M} be a cofibrantly generated semimodel category, with sets of generating (trivial) cofibrations I and J , such that U preserves filtered colimits. Assume that, for every (trivial) cofibration $i : K \rightarrow L$ between cofibrant objects in \mathbb{M} , and every pushout*

$$(2.2.2) \quad \begin{array}{ccc} F(K) & \xrightarrow{F(i)} & F(L) \\ g \downarrow & & \downarrow \\ A & \xrightarrow{p} & B \end{array}$$

where $A \in \text{Alg}_{\mathcal{T}}$ is an FI -cell complex such that $U(A)$ is cofibrant in \mathbb{M} , the morphism $U(p)$ is a (trivial) cofibration in \mathbb{M} . Then

- (1) $\text{Alg}_{\mathcal{T}}$ admits a transferred cofibrantly generated semimodel structure with generating (trivial) cofibrations FI and FJ ;
- (2) The functor U maps cofibrations with a cofibrant domain to cofibrations;
- (3) If $\mathcal{T}(0)$ is a cofibrant object in \mathbb{M} then U preserves cofibrant objects.

Proof. The proof proceeds exactly as in [Fre09]. The categorical argument in [Fre09, Lemma 12.1.5] demonstrates that the assumption in (2.2.2) holds for every (trivial) cofibration, even if K and L are not cofibrant. That FI (resp. FJ) permits the small object argument follows from a cellular extension argument in \mathbb{M} , the fact that I (resp. J) permits the small object argument in \mathbb{M} , and an adjunction argument. For the case of FJ , it is easy to check that all the objects $U(B_i)$ and L_i in [Fre09, Proposition 11.1.14] are cofibrant in \mathbb{M} , under our hypothesis on A , and hence that the required factorisations exist in \mathbb{M} . The key point for the existence of the semimodel structure on $\text{Alg}_{\mathcal{T}}$ is that the J part of the assumption in (2.2.2) implies the hypothesis that relative FJ -cell complexes with cofibrant domain are weak equivalences, so we can use Theorem 2.2.1. As for the verification of (2) and (3), this proceeds exactly as in [Fre09, Proposition 11.1.14], and only relies on the I part of the assumption in (2.2.2). \square

The verification of the hypotheses of Proposition 2.2.2 is easier when the domains of I and J are cofibrant, as we can then reduce to analyzing (2.2.2) for maps i in I and J . Procedures for creating cofibrantly generated semimodel structures, where the domains of the generating trivial cofibrations J are cofibrant, can be found in [BW20, Theorem B] and in [WY18, Theorem 6.3.1].

3. LEFT BOUSFIELD LOCALISATIONS AND THEIR LIFTINGS

Left Bousfield localisation is a fundamental tool that allows us to study the homotopy theory of a model category \mathbb{M} after a chosen class of morphisms \mathcal{C} is homotopically inverted [Hir03]. Formally, a left localisation of a model category \mathbb{M} with respect to a chosen class of morphisms \mathcal{C} is a new model category $L_{\mathcal{C}}\mathbb{M}$ and a left Quillen functor $j : \mathbb{M} \rightarrow L_{\mathcal{C}}\mathbb{M}$ that is the universal left Quillen functor out of \mathbb{M} that takes morphisms in \mathcal{C} to weak equivalences. We call the weak equivalences of $L_{\mathcal{C}}\mathbb{M}$ the *\mathcal{C} -local equivalences*. A particular construction of $L_{\mathcal{C}}\mathbb{M}$ is given by left Bousfield localisation, where j is the identity on \mathbb{M} , the cofibrations of $L_{\mathcal{C}}\mathbb{M}$ are the same as those of \mathbb{M} , where the \mathcal{C} -local equivalences are defined from \mathcal{C} using simplicial mapping spaces [Hir03, Chapter 3], and where the \mathcal{C} -local fibrations are defined via the right lifting property.

Definition 3.0.1. We will say that a model category \mathbb{M} *admits a localisation* with respect to a chosen class of morphisms \mathcal{C} if the classes of \mathcal{C} -local equivalences, cofibrations, and \mathcal{C} -local fibrations, satisfy the axioms of a semimodel category.

Local equivalences and local objects are defined with respect to simplicial mapping spaces (which exist even if \mathbb{M} is only a semimodel category). Recall from [Hir03, Chapter 3] that an object W is called *\mathcal{C} -local* if $map(f, W)$ is a weak equivalence of simplicial sets for all $f \in \mathcal{C}$. And, a morphism g in \mathbb{M} is a *\mathcal{C} -local equivalence* if $map(g, W)$ is a weak equivalence for all \mathcal{C} -local objects W . We will always assume we are localising a set \mathcal{C} of cofibrations, but this is no loss of generality, thanks to cofibrant replacement.

As is the case for transferred model structures, $L_{\mathcal{C}}\mathbb{M}$ admits a semimodel structure much more frequently than a model structure. In our setting, the model categories of n -operads are not known to be left proper, but they still admit a localisation in the semimodel categorical sense [BW20], and this is enough for our purposes. For the reader's convenience, we restate the main theorem from [BW20], which we will need in Section 13.

Theorem 3.0.2. *Suppose that \mathbb{M} is a combinatorial semimodel category whose generating cofibrations have cofibrant domain, and \mathcal{C} is a set of morphisms of \mathbb{M} . Then there is a semimodel structure $L_{\mathcal{C}}(\mathbb{M})$ on \mathbb{M} , whose weak equivalences are the \mathcal{C} -local equivalences, whose cofibrations are the same as \mathbb{M} , and whose fibrant objects are the \mathcal{C} -local objects. Furthermore, $L_{\mathcal{C}}(\mathbb{M})$ satisfies the universal property that, for any any left Quillen functor of semimodel categories $F : \mathbb{M} \rightarrow \mathbb{N}$ taking \mathcal{C} into the weak equivalences of \mathbb{N} , then F is a left Quillen functor when viewed as $F : L_{\mathcal{C}}(\mathbb{M}) \rightarrow \mathbb{N}$.*

Remark 3.0.3. The following notations for a pair of adjoint functors will be often use in our paper: $\alpha^* \vdash \alpha_!$. Here α^* is a right adjoint and $\alpha_!$ is its left adjoint.

We also have the following useful generalisation of [Hir03, Theorem 3.3.20]:

Theorem 3.0.4. *Let \mathbb{M} be a semimodel category and \mathcal{C} be a set of morphisms between cofibrant objects in \mathbb{M} such that the left Bousfield localisation $\mathbb{M} \rightarrow L_{\mathcal{C}}(\mathbb{M})$ exists. Let \mathbb{N} be a combinatorial semimodel categories whose generating cofibrations have cofibrant domains, and let*

$$\mathbb{N} \begin{array}{c} \xleftarrow{\alpha_!} \\ \xrightarrow{\alpha^*} \end{array} \mathbb{M}$$

be a Quillen adjunction. Then

- (1) There is a localisation $\mathbb{N} \rightarrow L_{\alpha_1, \mathcal{C}}(\mathbb{N})$ called the lifting of $\mathbb{M} \rightarrow L_{\mathcal{C}}(\mathbb{M})$ along α^* which makes the following commutative diagram a diagram of Quillen adjunctions:

$$\begin{array}{ccc} \mathbb{N} & \begin{array}{c} \xrightarrow{id} \\ \xleftarrow{id} \end{array} & L_{\alpha_1, \mathcal{C}}(\mathbb{N}) \\ \alpha_! \updownarrow \alpha^* & & \beta_! \updownarrow \beta^* \\ \mathbb{M} & \begin{array}{c} \xrightarrow{id} \\ \xleftarrow{id} \end{array} & L_{\mathcal{C}}(\mathbb{M}); \end{array}$$

- (2) The functor α^* reflects and preserves local fibrant objects. That is, a fibrant object $X \in \mathbb{N}$ is local if and only if $\alpha^*(X)$ is local in \mathbb{M} ;
- (3) If $\alpha^* \vdash \alpha_!$ is a pair of Quillen equivalences then $\beta^* \vdash \beta_!$ is also a pair of Quillen equivalences.

Proof. The proof of this theorem follows exactly the same patterns as the proof of [Hir03, Theorem 3.3.20]. The existence of the lifted localisation is guaranteed by Theorem 3.0.2. The proof of the statement about local objects is identical to the proof of Lemma 3.3 from [BW16], where it was proved for the forgetful functor from the category of algebras of a monad, but the argument relies only on the adjunction. \square

4. BECK-CHEVALLEY SQUARES

4.1. **Beck-Chevalley squares and homotopy Beck-Chevalley squares.** Recall [Mal0] that a square of right adjoints and a natural transformation as displayed below

$$(4.1.1) \quad \begin{array}{ccc} \mathbb{A} & \xleftarrow{\psi^*} & \mathbb{B} \\ \beta^* \downarrow & \searrow b & \downarrow \alpha^* \\ \mathbb{C} & \xleftarrow{\phi^*} & \mathbb{D} \end{array}$$

is called Beck-Chevalley if the natural transformation

$$(4.1.2) \quad \mathbf{bc} : \phi_! \beta^* \rightarrow \alpha^* \psi_!$$

is an isomorphism. The natural transformation \mathbf{bc} is defined as vertical pasting

$$\begin{array}{ccc} \mathbb{A} & \xleftarrow{id} & \mathbb{A} \\ id \downarrow & \searrow \epsilon & \downarrow \psi_! \\ \mathbb{A} & \xleftarrow{\psi^*} & \mathbb{B} \\ \beta^* \downarrow & \searrow b & \downarrow \alpha^* \\ \mathbb{C} & \xleftarrow{\phi^*} & \mathbb{D} \\ \phi_! \downarrow & \searrow \eta & \downarrow id \\ \mathbb{C} & \xleftarrow{id} & \mathbb{D} \end{array}$$

where η is the counit and ϵ is the unit of corresponding adjunctions.

Agreement 4.1.1. In all our applications the natural transformation b is the identity, so we will assume in the rest of the paper that the square of right adjoints (4.1.1) strictly commutes.

The following property of Beck-Chevalley squares allows us to lift equivalences along right adjoints.

Proposition 4.1.2. *Let (4.1.1) be a Beck-Chevalley square. Assume that $(\phi_!, \phi^*)$ is a pair of adjoint equivalences, and that the right adjoint functors β^* and α^* reflect isomorphisms. Then $(\psi_!, \psi^*)$ is a pair of adjoint equivalences.*

Proof. We must only prove that the unit and counit for $(\psi_!, \psi^*)$ are isomorphisms.

We begin with the counit. The Beck-Chevalley condition tells us that, in \mathbb{D} , $\alpha^*\psi_!Y \cong \phi_!\beta^*Y$ for every Y in \mathbb{A} . It follows that $\alpha^*\psi_!\psi^*X \cong \phi_!\beta^*\psi^*X \cong \phi_!\phi^*\alpha^*X$ for any $X \in \mathbb{B}$ and this is isomorphic to α^*X because $(\phi_!, \phi^*)$ is an equivalence. Since α^* reflects isomorphisms, the counit $\psi_!\psi^*X \rightarrow X$ is an isomorphism.

We turn to the unit. We first apply β^* , and then observe that $\beta^*(\psi^*\psi_!X) \cong \phi^*\alpha^*\psi_!X$. The Beck-Chevalley condition tells us that the latter is isomorphic to $\phi^*\phi_!\beta^*X$. Again using that $(\phi_!, \phi^*)$ is an adjoint equivalence, we see that $\beta^*X \rightarrow \phi^*\phi_!X \cong \beta^*\psi^*\psi_!X$ is an isomorphism. Since β^* reflects isomorphisms, the composite isomorphism above shows that the unit $X \rightarrow \psi^*\psi_!X$ is an isomorphism, as required. \square

Suppose now (4.1.1) is a commutative square of Quillen adjunctions between semimodel categories.

Definition 4.1.3. We say that the square above is a homotopy Beck-Chevalley square if it generates a Beck-Chevalley square of homotopy categories, that is, the morphisms between the derived functors

$$\mathbb{L}\phi_!\mathbb{R}\beta^*(-) \rightarrow \mathbb{R}\alpha^*\mathbb{L}\psi_!(-)$$

is an isomorphism.

The next proposition gives a practical criteria for recognition of homotopy Beck-Chevalley squares.

Proposition 4.1.4. *Let (4.1.1) be a Beck-Chevalley square and let the functor α^* preserve weak equivalences and β^* preserve cofibrant objects. Then (4.1.1) is also a homotopy Beck-Chevalley square.*

Proof. Let X be a fibrant and cofibrant object from \mathbb{A} . Because β^* preserves cofibrancy, we see that $\mathbb{L}\phi_!\mathbb{R}\beta^*(X) \cong \phi_!\beta^*(X)$. Also, $\mathbb{R}\alpha^*\mathbb{L}\psi_!(X) \cong \mathbb{R}\alpha^*\psi_!(X)$ because X is cofibrant. The object $\psi_!(X)$ need not be fibrant, so we must compute $\mathbb{R}\alpha^*\psi_!(X)$ via the fibrant replacement $\psi_!(X) \rightarrow R\psi_!(X)$, which induces a morphism $\alpha^*\psi_!X \rightarrow \alpha^*R\psi_!X$. Because α^* preserves weak equivalences, this morphism is a weak equivalence. Hence the composite $\phi_!\beta^*(X) \rightarrow \alpha^*\psi_!(X) \rightarrow \alpha^*R\psi_!(X)$ is a weak equivalence because the first morphism is an isomorphism. This finishes the proof. \square

4.2. Lifting of Quillen equivalences. Immediately from Proposition 4.1.2 we have the following property of homotopy Beck-Chevalley squares.

Proposition 4.2.1. *Let a square (4.1.1) be a homotopy Beck-Chevalley square. Assume that $(\phi_!, \phi^*)$ is a pair of Quillen equivalences, and that the right adjoints β^* and α^* reflect weak equivalences between fibrant objects. Then $(\psi_!, \psi^*)$ is a pair of Quillen equivalences.*

Proof. From the condition on β^* and α^* we see that the right derived functors $\mathbb{R}\beta^*$ and $\mathbb{R}\alpha^*$ reflect isomorphisms. \square

Finally, we combine everything together in the following Theorem.

Theorem 4.2.2. *Let (4.1.1) be a Beck-Chevalley square of Quillen adjunctions in which $(\phi_!, \phi^*)$ is a pair of Quillen equivalences, α^* preserves weak equivalences, β^* preserves cofibrant objects and both α^* and β^* reflect weak equivalences between fibrant objects. Then the pair $(\psi_!, \psi^*)$ is a pair of Quillen equivalences.*

Corollary 4.2.3. *Let (4.1.1) be a Beck-Chevalley square of Quillen adjunctions in which semimodel structures on \mathbb{A} and \mathbb{B} are obtained as transfers along α^* and β^* correspondingly and β^* preserves cofibrant objects. Then if $(\phi_!, \phi^*)$ is a pair of Quillen equivalences, the pair $(\psi_!, \psi^*)$ is also a pair of Quillen equivalences.*

Part 2. Semimodel structures for algebras of substitutes

In this part, we introduce a series of definitions that allow us to encode the type of algebraic structure we are interested in, and we prove a general Transfer Theorem (Theorem 8.1.7) to endow categories of algebras with transferred semimodel structures.

5. SUBSTITUTES, CONVOLUTION AND POLYNOMIAL MONADS

5.1. Substitudes. Let $\mathbb{V} = (\mathbb{V}, \otimes, I)$ be a symmetric monoidal category. We will assume by default that it is cocomplete and closed. For a small \mathbb{V} -category A let $[A, \mathbb{V}]$ denote the \mathbb{V} -category of \mathbb{V} -functors.

Definition 5.1.1 (Day-Street [DS03b]). A \mathbb{V} -*substitute* (P, A) is a small \mathbb{V} -category A together with a sequence of \mathbb{V} -functors:

$$P_n : \underbrace{A^{op} \otimes \cdots \otimes A^{op}}_{n\text{-times}} \otimes A \rightarrow \mathbb{V}, \quad n \geq 0,$$

equipped with

- (1) a \mathbb{V} -natural family of substitution operations

$$\begin{aligned} \mu : P(a_1, \dots, a_n; a) \otimes P(a_{11}, \dots, a_{1m_1}; a_1) \otimes \cdots \otimes P(a_{n1}, \dots, a_{nm_n}; a_n) \rightarrow \\ \rightarrow P(a_{11}, \dots, a_{nm_n}; a) \end{aligned}$$

- (2) a \mathbb{V} -natural family of morphisms (unit of substitute)

$$\eta : A(a_1, a_2) \rightarrow P_1(a_1; a_2);$$

- (3) for each permutation $\sigma \in S_n$ a \mathbb{V} -natural family of isomorphisms

$$\gamma_\sigma : P(a_1, \dots, a_n; a) \rightarrow P(a_{\sigma(1)}, \dots, a_{\sigma(n)}; a),$$

satisfying the obvious associativity, unitality and equivariance conditions.

Notice that P_1 is a \mathbb{V} -monad on A in the bicategory of \mathbb{V} -bimodules (also known as \mathbb{V} -profunctors or \mathbb{V} -distributors). The Kleisli category of this monad is called *the underlying category of P* .

Definition 5.1.2. A morphism of substitutes $(P, A) \rightarrow (Q, B)$ is a pair (f, g) where $g : A \rightarrow B$ is a \mathbb{V} -functor and f is a sequence of \mathbb{V} -natural transformations

$$f_n : P_n \rightarrow g^*(Q_n)$$

and g^* is the restriction functor along $(g^{op})^n \otimes g$ which respects substitution and unit operations in an obvious sense.

The concept of substitute generalizes operads and symmetric lax-monoidal categories. Indeed, any coloured operad \mathcal{E} in \mathbb{V} can be naturally considered as a substitute in several different ways [DS03a, BKW18].

One can consider a substitute $(P(\mathcal{E}), A)$ with A equal the \mathbb{V} -category of all unary operations in \mathcal{E} and $P(\mathcal{E})(a_1, \dots, a_n, a) = \mathcal{E}(a_1, \dots, a_n, a)$. The substitution operation in the coloured operad \mathcal{E} makes the assignment $P(\mathcal{E})(a_1, \dots, a_n; a)$ a \mathbb{V} -functor

$$P(\mathcal{E})_n : \underbrace{A^{op} \otimes \dots \otimes A^{op}}_{n\text{-times}} \otimes A \rightarrow \mathbb{V}, \quad n \geq 0, \quad .$$

The category $A = U(\mathcal{E})$ is also called the underlying category of the coloured operad \mathcal{E} .

In fact, a substitute in general is a coloured operad \mathcal{E} together with a small \mathbb{V} -category A and an identity-on-objects \mathbb{V} -functor $\eta : A \rightarrow U(\mathcal{E})$ [DS03a, Prop. 6.3]. In particular, given a substitute (P, A) one can form a substitute (P_0, A_0) , where A_0 is the maximal discrete subcategory of A and P_0 is the restriction of P to A_0 .

We refer the reader to [BKW18] for a detailed treatment of the relationships between substitutes, regular patterns of Getzler [Get10], operads and Feynman categories.

Definition 5.1.3. Let (P, A) be a \mathbb{V} -substitute. An algebra of (P, A) is a \mathbb{V} -presheaf $X \in [A, \mathbb{V}]$ equipped with the sequence of natural transformations:

$$P(a_1, \dots, a_n; a) \otimes X(a_1) \otimes \dots \otimes X(a_n) \rightarrow X(a)$$

satisfying natural commutativity, unitarity and equivariance conditions.

A morphism of (P, A) -algebras is a morphism of presheaves over A which commutes with all structure maps. (P, A) -algebras and their morphisms form a category $\text{Alg}_{(P,A)}(\mathbb{V})$.

Following [DS03a, DS03b] let us define the convolution operation. For the presheaves $X_1, \dots, X_k \in [A, \mathbb{V}]$ the convolution k -th product is given by the formula

$$\otimes_P^k(X_1, \dots, X_k)(-) = \int^{a_1, \dots, a_k} P(a_1, \dots, a_k; -) \otimes X_1(a_1) \otimes \dots \otimes X_k(a_k).$$

Remark 5.1.4. The convolution formula for $k = 0$ amounts to $\otimes_P^0 = P(\emptyset; -)$, that is, the underlying object of the algebra of nullary operations of P , which is the initial object in $\text{Alg}_P(\mathbb{V})$. For $k = 1$ the convolution $\otimes_P^1(X) = \eta_1(X)$ is the left Kan extension of the presheaf X along the unit of the substitute.

Convolution determines a symmetric lax monoidal structure on the category $[A, \mathbb{V}]$ [DS03b]. The free (P, A) -algebra monad \mathcal{T}_P on $[A, \mathbb{V}]$ can be expressed in terms of convolution:

$$(5.1.1) \quad \mathcal{T}_P(X) = \coprod_{k \geq 0} \otimes_P^k(X, \dots, X) / S_k.$$

It is useful to remember

Proposition 5.1.5. *The following \mathbb{V} -categories are isomorphic:*

- (1) *The category of algebras of the substitute (P, A) ;*
- (2) *The category of algebras $\text{Alg}_{\mathcal{T}_P}(\mathbb{V})$ of the monad \mathcal{T}_P ;*
- (3) *The category of commutative monoids in $[A, \mathbb{V}]$ with the lax-monoidal structure determined by the convolution.*

Proof. See [MS04b, DS03a, DS03b, BB17]. □

In view of this Proposition we will call (P, A) -algebras simply P -algebras if it does not lead to confusion, and the category of (P, A) -algebras will be identified with $\text{Alg}_{\mathcal{T}_P}(\mathbb{V})$ and denoted $\text{Alg}_P(\mathbb{V})$. If $\mathbb{V} = \text{Set}$ we will write simply Alg_P .

5.2. Convolution through Grothendieck construction. From now on we assume that the substitutes we use are Set -based substitutes. Given such a substitute (P, A) one can construct a \mathbb{V} -enriched substitute

$$(P \otimes I, A \otimes I)$$

by

$$A \otimes I(a, b) = \coprod_{A(a, b)} I; \quad P \otimes I(a_1, \dots, a_k; a) = \coprod_{P(a_1, \dots, a_k; a)} I.$$

We can then speak about algebras of P in \mathbb{V} (being algebras of $(P \otimes I, A \otimes I)$). To shorten notations we will denote the enriched substitute by the same letters (P, A) believing that this does not lead to confusion.

For a Set -based substitute (P, A) there is a way to describe the convolution operation using the two sided Grothendieck construction, which goes back to the Max Kelly's notion of a club [Kel74, FGHW08].

Recall that a *bimodule* from B to A is a functor

$$(5.2.1) \quad F : B^{op} \times A \rightarrow \text{Set}.$$

Every bimodule F generates a two-sided categorical fibration

$$(5.2.2) \quad B \xleftarrow{P} \int F \xrightarrow{\pi} A$$

as follows. The objects of $\int F$ are triples (b, a, f) where $(b, a) \in \text{Ob}(B^{op} \times A)$ and $f \in F(b, a)$. A morphism in $\int F$ is a commutative square

$$(5.2.3) \quad \begin{array}{ccc} b & \xrightarrow{f} & a \\ \phi \downarrow & & \downarrow \psi \\ b' & \xrightarrow{f'} & a' \end{array}$$

in the sense that the assignments $F(b, a) \times A(a, a') \rightarrow F(b, a')$ and $B(b, b') \times F(b', a') \rightarrow F(b, a')$ produce the same element $g \in F(b, a')$, from (f, ϕ) and (ψ, f') . The category $\int F$ is called the two-sided Grothendieck construction of F .

Let \mathbf{MA} be the free strict monoidal category on A and \mathbf{SA} be the free strict symmetric monoidal category on A . From the universal property we have a canonical monoidal functor $\epsilon : \mathbf{MA} \rightarrow \mathbf{SA}$.

The data for the substitute (P, A) (without substitution and unit) is the same as a bimodule

$$P : (\mathbf{SA})^{op} \times A \rightarrow \mathbf{Set}.$$

By precomposing with $\epsilon \times 1$ we also have another bimodule

$$(\epsilon \times 1)^* P : (\mathbf{MA})^{op} \times A \rightarrow \mathbf{Set}.$$

The bimodule P induces a two-sided categorical fibration

$$(5.2.4) \quad \mathbf{SA} \xleftarrow{p} \int P \xrightarrow{\pi} A$$

Explicitly, the category $\int P$ has objects the multimorphisms $e \in P(a_1, \dots, a_n; a)$ which we denote $a_1 \dots a_n \xrightarrow{e} a$. A morphism from $a_1 \dots a_n \xrightarrow{e} a$ to $b_1 \dots b_n \xrightarrow{h} b$ is given by a permutation $\sigma \in S_n$, an n -tuple $f_i : a_{\sigma(i)} \rightarrow b_i$, and $f : a \rightarrow b$ such that the square

$$(5.2.5) \quad \begin{array}{ccc} a_{\sigma(1)} \dots a_{\sigma(n)} & \xrightarrow{\sigma(e)} & a \\ f_1 \dots f_n \downarrow & & \downarrow f \\ b_1 \dots b_n & \xrightarrow{h} & b \end{array}$$

commutes in the same sense as in (5.2.3). The projection p sends a multimorphism to its domain and π sends it to the codomain.

Similarly, the underlying bimodule $(\epsilon \times 1)^* P$ induces a two-sided fibration

$$(5.2.6) \quad \mathbf{MA} \xleftarrow{up} \int (\epsilon \times 1)^* P \xrightarrow{u\pi} A.$$

Now, let $X : A \rightarrow \mathbb{V}$ be a presheaf. By the universal property of \mathbf{S} , X induces a symmetric monoidal functor

$$\mathbf{S}(X) : \mathbf{SA} \rightarrow \mathbb{V}, \quad \mathbf{S}(X)(a_1, \dots, a_k) = X(a_1) \otimes \dots \otimes X(a_k).$$

So, we have a functor:

$$\widetilde{(-)} : [A, \mathbb{V}] \rightarrow \mathbf{SymMon}(\mathbf{SA}, \mathbb{V}) \rightarrow [\mathbf{SA}, \mathbb{V}].$$

Analogously, we have a functor

$$\widetilde{(-)}' : [A, \mathbb{V}] \rightarrow [\mathbf{MA}, \mathbb{V}].$$

This functor factorises as the following composite

$$[A, \mathbb{V}] \xrightarrow{\Delta} \prod_{k \geq 0} ([A, \mathbb{V}]^k) \xrightarrow{\prod_k \tilde{\otimes}^k} \prod_k [A^k, \mathbb{V}] \simeq [\mathbf{MA}, \mathbb{V}],$$

where Δ for the factor $[A, \mathbb{V}]^k$ is the diagonal functor, i.e. it is a restriction functor induced by the canonical functor $\prod_1^k A \rightarrow A$ (the folding map) and

$$\tilde{\otimes}^k (X_1, \dots, X_k)(a_1, \dots, a_n) = X(a_1) \otimes \dots \otimes X(a_n).$$

Lemma 5.2.1. *For a substitute (P, A) , the k -th convolution tensor product \otimes_P^k is isomorphic to the composite*

$$(5.2.7) \quad [A, \mathbb{V}]^k \xrightarrow{\tilde{\otimes}^k} [A^k, \mathbb{V}] \xrightarrow{up^*} [\int(\epsilon \times 1)^* P, \mathbb{V}] \xrightarrow{(u\pi)!} [A, \mathbb{V}].$$

The functor part of the monad \mathcal{T}_P on $[A, \mathbb{V}]$ is isomorphic to the composite

$$(5.2.8) \quad [A, \mathbb{V}] \xrightarrow{\tilde{(-)}} [SA, \mathbb{V}] \xrightarrow{p^*} [\int P, \mathbb{V}] \xrightarrow{\pi!} [A, \mathbb{V}].$$

Proof. The first claim is a result in [DS03a, Section 7]. The second result is immediate from the definition of \mathcal{T}_P and $\tilde{(-)}$. □

Definition 5.2.2. A Set-substitute (P, A) is called a Σ -free substitute if there exists a bimodule

$$(5.2.9) \quad d(P) : (\mathbf{MA})^{op} \times A \rightarrow \mathbf{Set},$$

such that P is the left Kan extension of $d(P)$ along

$$\epsilon \times 1 : (\mathbf{MA})^{op} \times A \rightarrow (\mathbf{SA})^{op} \times A.$$

Remark 5.2.3. It is not true in general that $d(P) \cong (\epsilon \times 1)^* P$ for a Σ -free substitute (P, A) . This can happen, however, if (P, A) as a symmetric substitute is obtained as a symmetrisation of a nonsymmetric substitute [DS03b, Section 4].

If (P, A) is Σ -free then the bimodule $d(P)$ provides us with yet another two-sided fibration:

$$(5.2.10) \quad \mathbf{MA} \xleftarrow{p'} \int d(P) \xrightarrow{\pi'} A.$$

Lemma 5.2.4. *Let (P, A) be a Σ -free Set-substitute. Then the k -th convolution \otimes_P^k is isomorphic to the symmetrization of the following composite functor*

$$(5.2.11) \quad \odot_P^k : [A, \mathbb{V}]^k \xrightarrow{\tilde{\otimes}^k} [A^k, \mathbb{V}] \xrightarrow{(p')^*} [\int d(P), \mathbb{V}] \xrightarrow{\pi'_!} [A, \mathbb{V}].$$

Furthermore,

$$(5.2.12) \quad \mathcal{T}_P(X) = \pi'_!((p')^*(\tilde{X}')) = \coprod_{k \geq 0} \odot_P^k(X, \dots, X).$$

Proof. Using a classical formula for left Kan extensions, we compute the value of $(\epsilon \times 1)^* P(\bar{a}, a) := (\epsilon \times 1)^*(\epsilon \times 1)_! d(P)(a_1, \dots, a_k, a)$ as

$$(\epsilon \times 1)^* P(\bar{a}, a) = \operatorname{colim}_{(\epsilon \times 1)/(\bar{a}, a)} d(\tilde{P}).$$

It is not hard to see that the comma-category $(\epsilon \times 1)/(\bar{a}, a)$ is just a coproduct of copies $(\mathbf{MA})^{op} \times A/(\bar{a}, a)$ indexed by elements $\sigma \in \mathbf{S}_k$.

Hence, $\int(\epsilon \times 1)^* P$ decomposes as a coproduct of $k!$ copies of $\int d(P)$, and the result now follows from Lemma 5.2.1 and the definition of symmetrization [DS03b, Section 4]. The second part of the lemma is immediate from the formula 5.1.1 applied to the symmetrisation of $\odot_P^{(-)}$. □

Definition 5.2.5. For a Σ -free substitute (P, A) , we call the sequence of multi-functors $\odot_P^k, k \geq 0$ the nonsymmetric convolution of (P, A) .

Remark 5.2.6. If (P, A) is itself obtained as symmetrisation of a nonsymmetric substitute (Q, A) , then the nonsymmetric convolution of (P, A) coincides with the convolution of (Q, A) and, in particular, this is a lax-monoidal (nonsymmetric) structure on $[A, \mathbb{V}]$. But in general, the nonsymmetric convolution of a symmetric Σ -free substitute does not provide any lax-monoidal structure.

6. SUBSTITUTES AND INTERNAL ALGEBRA CLASSIFIERS

6.1. Σ -free substitutes and polynomial monads. Let (P, A) be a Σ -free Set -substitute. Recall that A_0 means the maximal discrete subcategory of A . Let also $i : A_0 \rightarrow A$ be the inclusion. We then have a composite of forgetful functors

$$\eta_0^* : \text{Alg}_P(\text{Set}) \xrightarrow{\eta^*} [A, \text{Set}] \xrightarrow{i^*} [A_0, \text{Set}]$$

which is monadic with left adjoint

$$(\eta_0)_! : [A_0, \text{Set}] \xrightarrow{i_!} [A, \text{Set}] \xrightarrow{\eta_!} \text{Alg}_P(\text{Set}).$$

Since (P, A) is Σ -free the monad \mathcal{P} on $[A_0, \text{Set}]$ generated by this adjunction is cartesian and, hence, is a finitary polynomial monad [BB17]. This is an important observation which allows us to use the full force of the theory of internal algebra classifiers developed in [Bat07, Bat08, BB17, BL17].

We briefly recall the main definitions and facts about finitary polynomial monads which we will need in the next section.

Let T_0 be a set. A polynomial monad $\mathcal{T} = (\mathcal{T}, \mu, \epsilon)$ is a monad on the category $\text{Set}/T_0 \cong [T_0, \text{Set}]$ whose functor part is generated by a polynomial

$$T_0 \longleftarrow^s E \xrightarrow{p} B \xrightarrow{t} T_0$$

and whose multiplication $\mu : \mathcal{T}^2 \rightarrow \mathcal{T}$ and unit $\epsilon : \mathcal{T}_0 = \text{Id}_{T_0} \rightarrow \mathcal{T}t$ are cartesian natural transformations. Here, Id_{T_0} is the identity monad on $[T_0, \text{Set}]$ which we will denote \mathcal{T}_0 for convenience. The functor $\mathcal{T} : \text{Set}/T_0 \rightarrow \text{Set}/T_0$ generated by the polynomial is the composite

$$[T_0, \text{Set}] \xrightarrow{s^*} [E, \text{Set}] \xrightarrow{p_*} [B, \text{Set}] \xrightarrow{t_!} [T_0, \text{Set}]$$

where s^* is the restriction along s , p_* is the right Kan extension along p , and $t_!$ is the left Kan extension along t . Explicitly the functor \mathcal{T} is given by the formula

$$\mathcal{T}(X)(i) = \coprod_{b \in t^{-1}(i)} \prod_{e \in p^{-1}(b)} X(s(e)),$$

which explains the name ‘polynomial’ since it is a sum of products of formal variables. The set T_0 is called the set of colours (or objects) of \mathcal{T} and the set B is called the set of operations of \mathcal{T} .

A polynomial monad is finitary if all preimages of the map $p : E \rightarrow B$ are finite sets. We will be considering only finitary polynomial monads and so it will be convenient to call them simply polynomial monads.

Polynomial monads and their cartesian morphisms form a category. Such a cartesian morphism $\phi : \mathcal{T} \rightarrow \mathcal{S}$ is completely determined by a commutative diagram

in \mathbf{Set}

$$\begin{array}{ccccc} T_0 & \xleftarrow{s} & E & \xrightarrow{p} & B & \xrightarrow{t} & T_0 \\ \downarrow & & \downarrow & & \downarrow & & \downarrow \\ S_0 & \xleftarrow{s'} & D & \xrightarrow{p'} & C & \xrightarrow{t'} & S_0 \end{array}$$

such that the middle square is a pullback.

Any small category A generates a polynomial monad, which we will denote \mathcal{A} . The corresponding polynomial is given by

$$A_0 \xleftarrow{s} A_1 \xrightarrow{id} A_1 \xrightarrow{t} A_0$$

where A_1 is the set of morphisms of A .

The data of a Σ -free polynomial (P, A) amounts, therefore, to an identity-on-objects cartesian map of polynomial monads $\eta : \mathcal{A} \rightarrow \mathcal{P}$, represented by a commutative diagram

$$\begin{array}{ccccc} & & A_1 & \xrightarrow{id} & A_1 & & \\ & s \swarrow & \downarrow & & \downarrow & \searrow t & \\ A_0 & \xleftarrow{s} & E & \xrightarrow{p} & B & \xrightarrow{t} & A_0 \end{array}$$

in which the central square is a pullback. Observe also that there is an isomorphism of sets of elements $b \in B$ such that $t(b) = a \in A_0$, $s(p^{-1}(b)) = \{a_1, \dots, a_k\} \subset A_0$ and the cardinality $p^{-1}(b) = n$ and the set $\coprod d(P)(a_{i_1}, \dots, a_{i_n}; a)$, where $d(P)$ is a bimodule (5.2.9) and coproduct is taken over all possible different strings of elements of $\{a_1, \dots, a_k\}$.

6.2. Internal algebra classifiers. Let \mathbb{V} be a cocomplete symmetric monoidal category and \mathcal{T} be a finitary polynomial monad. We can then construct a functor $\mathcal{T}^{\mathbb{V}} : [T_0, \mathbb{V}] \rightarrow [T_0, \mathbb{V}]$ as follows:

$$\mathcal{T}^{\mathbb{V}}(X)(a) = \coprod_{b \in t^{-1}(a)} \bigotimes_{e \in p^{-1}(b)} X_{s(e)}.$$

This defines a monad on $[T_0, \mathbb{V}]$.

Definition 6.2.1. The category of algebras of a polynomial monad \mathcal{T} in a cocomplete symmetric monoidal category \mathbb{V} is the category of algebras of the monad $\mathcal{T}^{\mathbb{V}}$.

Remark 6.2.2. To simplify the notation, the monad $\mathcal{T}^{\mathbb{V}}$ will be denoted simply \mathcal{T} . It is normally clear from the context in which category we consider our monad. The category of \mathcal{T} -algebras in \mathbb{V} will be denoted $\mathbf{Alg}_{\mathcal{T}}(\mathbb{V})$.

Algebras of polynomial monads in the symmetric monoidal category of small categories $(\mathbf{Cat}, \times, 1)$ will be called categorical \mathcal{T} -algebras. The category of categorical algebras of \mathcal{T} is isomorphic to the category of internal categories in the category of \mathcal{T} -algebras in \mathbf{Set} . The category of categorical \mathcal{T} -algebras is naturally a 2-category. We will use this fact but preserve the notation $\mathbf{Alg}_{\mathcal{T}}(\mathbf{Cat})$ for this 2-category.

A terminal internal category has a unique \mathcal{T} -algebra structure for any polynomial monad \mathcal{T} ; the latter promotes it to a terminal categorical \mathcal{T} -algebra. From now on *all terminal objects will be denoted 1* hoping that this will cause no confusion.

The following definitions are taken from [Bat08] and [BB17].

Definition 6.2.3. Let A be a categorical \mathcal{T} -algebra for a polynomial monad \mathcal{T} .

An internal \mathcal{T} -algebra in A is a lax-morphism of categorical \mathcal{T} -algebras from the terminal categorical \mathcal{T} -algebra to A .

Internal \mathcal{T} -algebras in A and \mathcal{T} -natural transformations form a category $\text{Int}_{\mathcal{T}}(A)$ and this construction extends to a 2-functor $\text{Int}_{\mathcal{T}} : \text{Alg}_{\mathcal{T}}(\text{Cat}) \rightarrow \text{Cat}$.

Given a cartesian map of polynomial monads $f : \mathcal{S} \rightarrow \mathcal{T}$ we have a restriction 2-functor $f^* : \text{Alg}_{\mathcal{T}}(\text{Cat}) \rightarrow \text{Alg}_{\mathcal{S}}(\text{Cat})$.

Definition 6.2.4. Let A be a categorical \mathcal{T} -algebra for a polynomial monad \mathcal{T} .

An internal \mathcal{S} -algebra in A is a lax-morphism of categorical \mathcal{S} -algebras from the terminal categorical \mathcal{S} -algebra to $f^*(A)$.

Internal \mathcal{S} -algebras in A and \mathcal{S} -natural transformations form a category $\text{Int}_{\mathcal{S}}(A)$ and this construction extends to a 2-functor

$$\text{Int}_{\mathcal{S}} : \text{Alg}_{\mathcal{T}}(\text{Cat}) \rightarrow \text{Cat}.$$

This 2-functor is representable and the categorical \mathcal{T} algebra which represents it is called the classifier of internal \mathcal{S} -algebras inside categorical \mathcal{T} -algebras. We denote it $\mathcal{T}^{\mathcal{S}}$.

Example 6.2.5. Let $f : \mathcal{S} \rightarrow \mathcal{T}$ be the cartesian monad map which comes from a functor $F : T \rightarrow S$ between small categories. In this case the classifier $\mathcal{T}^{\mathcal{S}}$ is the covariant presheaf on T with values in Cat for which $\mathcal{T}^{\mathcal{S}}(a) = F/a$, the classical comma-category of F over a .

For any symmetric monoidal category \mathbb{V} there is a way to consider it as a categorical pseudoalgebra of any polynomial monad \mathcal{T} , and then consider internal \mathcal{S} -algebras inside \mathbb{V} cf. [BB17, Section 6.8]. Moreover, the category $\text{Int}_{\mathcal{S}}(\mathbb{V})$ is isomorphic to $\text{Alg}_{\mathcal{S}}(\mathbb{V})$ [BB17, Proposition 6.9]. The universal property of $\mathcal{T}^{\mathcal{S}}$ in this case tells us that the category of \mathcal{S} -algebras in \mathbb{V} is isomorphic to the category of \mathcal{T} -functors $\mathcal{T}^{\mathcal{S}} \rightarrow \mathbb{V}$.

Now let $X \in \text{Alg}_{\mathcal{S}}(\mathbb{V})$ and $\tilde{X} : \mathcal{T}^{\mathcal{S}} \rightarrow \mathbb{V}$ be the morphism of categorical \mathcal{T} -algebras representing X . If \mathbb{V} is cocomplete symmetric monoidal category, the restriction functor $f^* : \text{Alg}_{\mathcal{T}}(\mathbb{V}) \rightarrow \text{Alg}_{\mathcal{S}}(\mathbb{V})$ has a left adjoint $f_! : \text{Alg}_{\mathcal{S}}(\mathbb{V}) \rightarrow \text{Alg}_{\mathcal{T}}(\mathbb{V})$. The following fact, which generalises the classical formula for pointwise left Kan extension, was proved in [BB17, Theorem 6.17]:

Theorem 6.2.6. *The underlying object of $f_!(X)$ is isomorphic to $\text{colim}_{\mathcal{T}^{\mathcal{S}}} \tilde{X}$.*

6.3. Exact and semiexact squares of polynomial monads. Recall [BL17, Proposition 4.7] that any commutative square of cartesian morphisms of polynomial monads

$$(6.3.1) \quad \begin{array}{ccc} \mathcal{A} & \xrightarrow{\phi} & \mathcal{B} \\ \beta \uparrow & \nearrow \gamma & \uparrow \alpha \\ \mathcal{C} & \xrightarrow{\psi} & \mathcal{D} \end{array}$$

induces a morphism of classifiers

$$(6.3.2) \quad \mathcal{D}^{\mathcal{C}} \rightarrow \alpha^*(\mathcal{B}^{\mathcal{A}}).$$

Definition 6.3.1. A commutative square (6.3.1) is exact if the corresponding map of classifiers (6.3.2) is a final functor of underlying categories.

This square is semiexact if there is a \mathcal{C} -categorical algebra τ and a \mathcal{C} -functor $\tau \rightarrow \psi^*(\mathcal{D}^{\mathcal{C}})$ such that the evaluation of the composite

$$(6.3.3) \quad \tau \rightarrow \psi^*(\mathcal{D}^{\mathcal{C}}) \rightarrow \gamma^*(\mathcal{B}^{\mathcal{A}})$$

on each object of \mathcal{C} is a final functor, and, moreover, the following square is a pullback

$$(6.3.4) \quad \begin{array}{ccc} \mathcal{C}(\tau) & \longrightarrow & \mathcal{C}(\psi^*(\mathcal{D}^{\mathcal{C}})) \\ \downarrow & & \downarrow \\ \tau & \longrightarrow & \psi^*(\mathcal{D}^{\mathcal{C}}). \end{array}$$

In this square the vertical morphisms are algebra structure morphisms.

Example 6.3.2. If polynomial monads in the square (6.3.1) correspond to small categories then the exactness of this square is equivalent to the exactness of the corresponding square of small categories in the sense of Guitart [Gui80]. Our terminology was inspired by this classical paper.

Lemma 6.3.3. *Any exact square is semiexact.*

Proof. We take as τ the classifier $\psi^*(\mathcal{D}^{\mathcal{C}})$. The only thing left to prove is the pullback condition for (6.3.4). It follows from the general property of classifiers for polynomial monads that this square is a pullback (cf. the proof of Theorem 5.7.2 in [Web16] or proof of Theorem 5.15 from [BB17]). \square

Theorem 6.3.4. *Let \mathbb{V} be a cocomplete symmetric monoidal category. If the square (6.3.1) is semiexact then in the induced square of adjunctions*

$$\begin{array}{ccc} \text{Alg}_{\mathcal{A}}(\mathbb{V}) & \begin{array}{c} \xrightarrow{\phi_!} \\ \xleftarrow{\perp} \\ \xrightarrow{\phi^*} \end{array} & \text{Alg}_{\mathcal{B}}(\mathbb{V}) \\ \beta_! \uparrow \downarrow \beta^* & & \alpha_! \uparrow \downarrow \alpha^* \\ \text{Alg}_{\mathcal{C}}(\mathbb{V}) & \begin{array}{c} \xrightarrow{\psi_!} \\ \xleftarrow{\perp} \\ \xrightarrow{\psi^*} \end{array} & \text{Alg}_{\mathcal{D}}(\mathbb{V}) \end{array}$$

the transformation

$$\psi^*(\mathbf{bc}) : \psi^*\psi_!\beta^* \rightarrow \gamma^*\phi_!$$

has a section.

If (6.3.1) is exact this square is a Beck-Chevalley square.

Proof. Let start from the second part of the Theorem. Let $X \in \text{Alg}_{\mathcal{A}}(\mathbb{V})$ and $\tilde{X} : \mathcal{B}^{\mathcal{A}} \rightarrow \mathbb{V}$ be the morphism of categorical \mathcal{B} -algebras representing X . Then the underlying object of $\phi_!(X)$ is isomorphic to $\text{colim}_{\mathcal{B}^{\mathcal{A}}} \tilde{X}$. Thus underlying object of $\alpha^*(\phi_!(X))$ is isomorphic to $\alpha^*(\text{colim}_{\mathcal{B}^{\mathcal{A}}} \tilde{X})$. Notice that α^* in the last formula means, in fact the composite of α^* and forgetful functor to the category of collections. This is clearly the same as $\text{colim}_{\alpha^*(\mathcal{B}^{\mathcal{A}})} \alpha^*(\tilde{X})$. Since (6.3.2) is final such a colimit is isomorphic to $\text{colim}_{\alpha^*(\mathcal{D}^{\mathcal{C}})} \alpha^*(\tilde{X})$ which in its turn isomorphic to the underlying object of $\psi_!(\beta^*(X))$.

For the first statement of the Theorem it is enough to observe that the pullback condition of 6.3.4 assures that this is an exact square in the sense of [Web16] because

the right vertical arrow is the discrete fibration [Web16, Proposition 4.3.4]. Hence the forgetful functor along $\tau \rightarrow \psi^*(\mathcal{D}^C)$ preserves pointwise left Kan extensions and we can proceed with the proof like before with the difference that we can only claim that Beck-Chevalley map is a retraction on underlying objects. \square

7. UNARY TAME SUBSTITUTES

In this section we generalise the theory of tame polynomial monads developed in [BB17]. From now on we will assume that all our substitutes are Σ -free. We will also assume that the unit of the substitute $\eta : A \rightarrow P_1$ is faithful (and it is the identity on objects by definition).

Remark 7.0.1. Many constructions below can be implemented without these two assumptions but this requires a lot more complicated and heavier classifiers techniques developed by Mark Weber in [Web16]. We choose to work in a simplified situation because the formulations and proofs are more transparent with these assumptions and because the majority of our examples are from this class.

7.1. Fiberwise disconnected morphisms of polynomial monads.

Definition 7.1.1. Let $\phi : \mathcal{T} \rightarrow \mathcal{S}$ be a cartesian morphism of monads. It will be called fiberwise disconnected if the following square of cartesian morphisms is semiexact:

$$(7.1.1) \quad \begin{array}{ccc} \mathcal{T} & \xrightarrow{\phi} & \mathcal{S} \\ \epsilon_\tau \uparrow & & \uparrow id \\ \mathcal{T}_0 & \longrightarrow & \mathcal{S} \end{array}$$

Lemma 7.1.2. *The following conditions are equivalent:*

- (1) ϕ is fiberwise disconnected;
- (2) The classifier $\mathcal{S}^{\mathcal{T}}$ contains a discrete final subcategory;
- (3) There is a reflective discrete subcategory in $\mathcal{S}^{\mathcal{T}}$;
- (4) The connected component functor $\mathcal{S}^{\mathcal{T}} \rightarrow \pi_0(\mathcal{S}^{\mathcal{T}})$ has a right adjoint;
- (5) The category $\mathcal{S}^{\mathcal{T}}$ is a coproduct of categories with terminal objects.

Proof. The equivalence of (2), (3), (4), (5) follows from [BB17, Lemma 7.6].

To prove that (1) implies (2) observe that the map of classifiers $\mathcal{S}^{\mathcal{T}_0} \rightarrow \mathcal{S}^{\mathcal{T}}$ is the identity on objects but $\mathcal{S}^{\mathcal{T}_0}$ is discrete. Let $i : \tau \rightarrow \mathcal{S}^{\mathcal{T}_0}$ be the functor from the definition of semiexactness. The condition that τ is a \mathcal{T}_0 -algebra just means that this is a \mathcal{T}_0 -family of categories. We can then factorise the \mathcal{T}_0 -algebra morphism i as $\tau \rightarrow \kappa \subset \mathcal{S}^{\mathcal{T}_0}$, where κ is the image of i . Obviously $\kappa \subset \mathcal{S}^{\mathcal{T}}$ is final. The inverse implication is clear. \square

To shorten our wording in the rest of the paper we will often call a fiberwise disconnected morphism simply *disconnected*.

7.2. Tame polynomial monads. Let us recall the definition of tameness for polynomial monads from [BB17].

Let \mathcal{T} be a finitary monad on a cocomplete category \mathbb{C} . Following [BB17] we denote by $\mathcal{T} + 1$ the finitary monad on $\mathbb{C} \times \mathbb{C}$ given by

$$\begin{aligned} (\mathcal{T} + 1)(X, Y) &= (\mathcal{T}X, Y) \\ (\mathcal{T} + 1)(\phi, \psi) &= (\mathcal{T}\phi, \psi) \end{aligned}$$

with evident multiplication and unit. Let $U_{\mathcal{T}}$ be the forgetful functor $\text{Alg}_{\mathcal{T}} \rightarrow \mathbb{C}$ and $F_{\mathcal{T}}$ be the free \mathcal{T} -algebra functor. The functor $R : \text{Alg}_{\mathcal{T}} \rightarrow \text{Alg}_{\mathcal{T}} \times \mathbb{C}$, $R(X) = (X, U_{\mathcal{T}}(X))$ has a left adjoint $L(X, K) = X \sqcup F_{\mathcal{T}}(K)$ where the coproduct is taken in the category of \mathcal{T} -algebras. We have a commutative square of adjunctions:

$$(7.2.1) \quad \begin{array}{ccc} \text{Alg}_{\mathcal{T}} \times \mathbb{C} & \begin{array}{c} \xrightarrow{L} \\ \perp \\ \xleftarrow{R} \end{array} & \text{Alg}_{\mathcal{T}} \\ \begin{array}{c} \uparrow F_{\mathcal{T}} \times \text{id}_{\mathbb{C}} \\ \downarrow U_{\mathcal{T}} \times \text{id}_{\mathbb{C}} \end{array} & & \begin{array}{c} \uparrow F_{\mathcal{T}} \\ \downarrow U_{\mathcal{T}} \end{array} \\ \mathbb{C} \times \mathbb{C} & \begin{array}{c} \xrightarrow{-\sqcup-} \\ \perp \\ \xleftarrow{\Delta_{\mathbb{C}}} \end{array} & \mathbb{C} \end{array}$$

If \mathbb{C} has pullbacks that commute with coproducts, and \mathcal{T} is a cartesian monad, then $\mathcal{T} + 1$ is a cartesian monad as well, and the adjoint square (7.3.2) induces a cartesian morphism $\mathcal{T} + 1 \rightarrow \mathcal{T}$.

If \mathcal{T} is a polynomial monad on $\mathbb{C} = [\mathcal{T}_0, \text{Set}]$ generated by the polynomial

$$\mathcal{T}_0 \xleftarrow{s} E \xrightarrow{p} B \xrightarrow{t} \mathcal{T}_0$$

then $\mathcal{T} + 1$ is a polynomial monad on $[\mathcal{T}_0 \sqcup \mathcal{T}_0, \text{Set}]$ generated by the polynomial:

$$\mathcal{T}_0 \sqcup \mathcal{T}_0 \xleftarrow{s \sqcup \text{id}} E \sqcup \mathcal{T}_0 \xrightarrow{p \sqcup \text{id}} B \sqcup \mathcal{T}_0 \xrightarrow{t \sqcup \text{id}} \mathcal{T}_0 \sqcup \mathcal{T}_0$$

and the adjoint square (7.3.2) for a polynomial monad \mathcal{T} on Set/I is induced by the following cartesian morphism of polynomials

$$\begin{array}{ccccccc} \mathcal{T}_0 \sqcup \mathcal{T}_0 & \xleftarrow{s \sqcup \text{id}} & E \sqcup \mathcal{T}_0 & \xrightarrow{p \sqcup \text{id}} & B \sqcup \mathcal{T}_0 & \xrightarrow{t \sqcup \text{id}} & \mathcal{T}_0 \sqcup \mathcal{T}_0 \\ \downarrow \nabla & & \downarrow \psi & \text{pb} & \downarrow \phi & & \downarrow \nabla_I \\ \mathcal{T}_0 & \xleftarrow{s} & E & \xrightarrow{p} & B & \xrightarrow{t} & \mathcal{T}_0 \end{array}$$

in which ∇ is the folding map, and ϕ (resp. ψ) is the identity on B (resp. E) and the unit η of \mathcal{T} on \mathcal{T}_0 .

Remark 7.2.1. At this moment it will be convenient to change a notation from [BB17]. So, we put:

$$\mathcal{T} + \mathcal{T}_0 := \mathcal{T} + 1.$$

Definition 7.2.2. [BB17] A polynomial monad \mathcal{T} is said to be *tame* if the morphism $\mathcal{T} + \mathcal{T}_0 \rightarrow \mathcal{T}$ is disconnected.

The classifier $\mathcal{T}^{\mathcal{T} + \mathcal{T}_0}$ classifies the so called *semifree coproducts* that is the coproducts $X \sqcup F_{\mathcal{T}}(K)$ in the category of \mathcal{T} -algebras where X is an arbitrary \mathcal{T} -algebras and $F_{\mathcal{T}}(K)$ a free \mathcal{T} -algebra on a collection $K \in [T_0, \text{Set}]$. This implies that for

We now have the following square of adjunctions generated by the cartesian map of monads above:

$$(7.3.2) \quad \begin{array}{ccc} \text{Alg}_{\mathcal{P}} \times [A, \text{Set}] & \begin{array}{c} \xrightarrow{L_{\mathcal{P}}} \\ \perp \\ \xleftarrow{R_{\mathcal{P}}} \end{array} & \text{Alg}_{\mathcal{P}} \\ \begin{array}{c} \uparrow \dashv \eta_0^* \times i^* \\ (\eta_0)_! \times i_! \\ \downarrow \dashv \eta_0^* \end{array} & & \begin{array}{c} \uparrow \dashv \eta_0^* \\ (\eta_0)_! \\ \downarrow \dashv \eta_0^* \end{array} \\ [A_0, \text{Set}] \times [A_0, \text{Set}] & \begin{array}{c} \xrightarrow{-\sqcup-} \\ \perp \\ \xleftarrow{\Delta} \end{array} & [A_0, \text{Set}] \end{array}$$

Here, the functor $R_{\mathcal{P}} : \text{Alg}_{\mathcal{P}} \rightarrow \text{Alg}_{\mathcal{P}} \times [A, \text{Set}]$ is $R(X) = (X, \eta^*(X))$ and its left adjoint is $L(X, K) = X \sqcup \eta_!(K)$, where η^* is the forgetful functor from $\text{Alg}_{\mathcal{P}}$ to $[A, \text{Set}]$ and $\eta_!$ its left adjoint as usual.

The morphism $\mathcal{P} + \mathcal{A}_0 \rightarrow \mathcal{P}$ factorises as $\mathcal{P} + \mathcal{A}_0 \rightarrow \mathcal{P} + \mathcal{A} \rightarrow \mathcal{P}$ and we have an induced map of classifiers

$$\mathcal{P}^{\mathcal{P} + \mathcal{A}_0} \rightarrow \mathcal{P}^{\mathcal{P} + \mathcal{A}}.$$

The classifier $\mathcal{P}^{\mathcal{P} + \mathcal{A}}$ has the same objects as $\mathcal{P}^{\mathcal{P} + \mathcal{A}_0}$ but more morphisms. Like in $\mathcal{P}^{\mathcal{P} + \mathcal{A}_0}$, a morphism $\mathbf{b}' \rightarrow \mathbf{b}$ is given by a set of elements $b_1, \dots, b_k \in B$ one for each X -coloured edge of \mathbf{b} , but also a list of elements $\alpha_1, \dots, \alpha_l \in A_1$ for each K -coloured edge such that $b' = b(\alpha_1, \dots, b_1, \alpha_i, \dots, b_k, \dots, \alpha_l)$, where the α_i correspond to K -edges and the b'_i s correspond to X -edges of \mathbf{b} . The corolla representing \mathbf{b}' is obtained from the corolla representing \mathbf{b} by replacing the i -th X -edge of \mathbf{b} with as many X -edges as the corresponding operation $b_i \in B$ has elements in its fiber $p^{-1}(b_i)$ as in $\mathcal{P}^{\mathcal{P}_0 + \mathcal{A}_0}$.

Replacing the monad \mathcal{P} by the monad \mathcal{A} in the construction (7.3.1) we obtain a new monad $\mathcal{A} + \mathcal{A}$ over \mathcal{P} . We have a commutative triangle of cartesian maps of polynomial monads:

$$(7.3.3) \quad \begin{array}{ccc} \mathcal{A} + \mathcal{A} & \xrightarrow{\quad} & \mathcal{P} + \mathcal{A} \\ & \searrow & \swarrow \\ & \mathcal{P} & \end{array}$$

This triangle induces a morphism of $\mathcal{P}^{\mathcal{A} + \mathcal{A}}$ to $\mathcal{P}^{\mathcal{P} + \mathcal{A}}$ which is the identity on objects and injective on morphisms. So, we can consider $\mathcal{P}^{\mathcal{A} + \mathcal{A}}$ as a subcategory of $\mathcal{P}^{\mathcal{P} + \mathcal{A}}$. We will call a morphism $\mathbf{b}' \rightarrow \mathbf{b}$ in $\mathcal{P}^{\mathcal{P} + \mathcal{A}}$ *unary* if it belongs to $\mathcal{P}^{\mathcal{A} + \mathcal{A}}$. Explicitly, a morphism $b' = b(\alpha_1, \dots, b_1, \alpha_i, \dots, b_k, \dots, \alpha_l)$ is unary if all elements $b_1, \dots, b_k \in B$ are unary operations in \mathcal{P} which come from morphisms of \mathcal{A} .

Definition 7.3.1. A substitute (P, A) is unary tame if the square

$$(7.3.4) \quad \begin{array}{ccc} \mathcal{P} + \mathcal{A} & \xrightarrow{\phi} & \mathcal{P} \\ \beta \uparrow & & \uparrow id \\ \mathcal{A} + \mathcal{A} & \xrightarrow{\psi} & \mathcal{P} \end{array}$$

is semiexact.

Lemma 7.3.2. A substitute (P, A) is unary tame if and only if there exists a morphism of A -presheaves in Cat

$$\lambda \rightarrow \eta^*(\mathcal{P}^{\mathcal{A} + \mathcal{A}})$$

such that the composite $\lambda \rightarrow \eta^*(\mathcal{P}^{A+A}) \rightarrow \eta^*(\mathcal{P}^{P+A})$ is a levelwise final functor and the square

$$(7.3.5) \quad \begin{array}{ccc} \mathcal{A}(\lambda) & \longrightarrow & \mathcal{A}(\eta^*(\mathcal{P}^{A+A})) \\ \downarrow & & \downarrow \\ \lambda & \longrightarrow & \eta^*(\mathcal{P}^{A+A}) \end{array}$$

is a pullback.

Proof. If such a λ exists we can take $\tau = (\lambda, \lambda)$ because

$$\psi^*(\mathcal{P}^{A+A}) = (\eta^*(\mathcal{P}^{A+A}), \eta^*(\mathcal{P}^{A+A})).$$

In the other direction, if $\tau \rightarrow \psi^*(\mathcal{P}^{A+A})$ satisfies the condition of semiexactness τ is, in fact, a pair of categorical A -presheaves (λ, λ') together with a morphism to $(\eta^*(\mathcal{P}^{A+A}), \eta^*(\mathcal{P}^{A+A}))$. It is not hard to see that either of λ and λ' satisfies the condition of lemma. \square

Example 7.3.3. If \mathcal{P} is tame as polynomial monad then (P, A_0) is a unary tame substitute. In this case the final subcategory in question is just the same discrete final subcategory in \mathcal{P}^{P+A_0} from the definition of tameness.

7.4. Semifree coproduct and convolution. We start from the following elementary observation. Consider the classifier \mathcal{P}^A . If X is an \mathcal{A} -algebra (in a cocomplete symmetric monoidal category \mathbb{V}), that is, a functor $A \rightarrow \mathbb{V}$, then we can construct a functor $\tilde{X} : \mathcal{P}^A \rightarrow \mathbb{V}$. The colimit of this functor computes the free P -algebra on X . Combining it with Lemma 5.2.4 we get a formula

$$\text{colim}_{\mathcal{P}^A} \tilde{X} \cong \coprod_n \odot_P^n(X, \dots, X).$$

We also can prove this formula by direct calculations knowing that the objects of \mathcal{P}^A correspond to the operations in P (that is, corollas as on the left in the picture (7.2.2)) and the functor \tilde{X} sends such an object to the corresponding value $X(s_1(b)) \otimes \dots \otimes X(s_k(b))$. Notice that we either choose a planar structure on the corollas to be able to fix the order in the tensor product above or, equivalently, take the colimit over the action of groupoid S_k on this object (that is, use the unordered tensor product). The resulting functors are canonically isomorphic. But in the first case we may think that the objects of \mathcal{P}^A are planar corollas and the order in the tensor product is taken according to their planar structures. Then we take the colimit over unary operations in A , which is exactly the definition of nonsymmetric convolution. Similarly we have the following

Lemma 7.4.1. *Let $(X, K) \in [A, \mathbb{V}] \otimes [A, \mathbb{V}]$. Then*

$$\text{colim}_{\mathcal{P}^{A+A}} \widetilde{(X, K)} \cong \coprod_{p, q \geq 0, \sigma \in Sh_{p, q}} \sigma(\odot_P^{p+q})(\underbrace{X, \dots, X}_p, \underbrace{K, \dots, K}_q)$$

Here, $Sh_{p, q}$ is the set of (p, q) -shuffles and

$$\sigma(\odot_P^n)(X_1, \dots, X_n) = \odot_P^n(X_{\sigma(1)}, \dots, X_{\sigma(n)}).$$

Proof. The only thing which requires explanation in this formula is the presence of the set of shuffles. It follows from the fact that we can take as objects of \mathcal{P}^{A+A}

two coloured planar corollas as shown in (7.2.3). Such coloured planar corollas are in one to one correspondence with (p, q) -shuffles. \square

This lemma implies the following relationships between semifree coproduct $X \sqcup \eta_!(K)$ and convolution.

Proposition 7.4.2. *Let (P, A) be a unary tame substitute and let $X \in \text{Alg}_P(\mathbb{V})$ and $K \in [A, \mathbb{V}]$. The underlying A -presheaf of the semifree coproduct $X \sqcup \eta_!(K)$ is naturally a retract of*

$$\coprod_{p, q \geq 0, \sigma \in \text{Sh}_{p, q}} \sigma(\odot_P^{p+q})(\underbrace{\eta^*(X), \dots, \eta^*(X)}_p, \underbrace{K, \dots, K}_q).$$

Proof. Consider the adjunction square generated by the semiexact square (7.3.4):

$$\begin{array}{ccc} \text{Alg}_{\mathcal{P}+\mathcal{A}}(\mathbb{V}) & \begin{array}{c} \xrightarrow{\phi_!} \\ \perp \\ \xleftarrow{\phi^*} \end{array} & \text{Alg}_{\mathcal{P}}(\mathbb{V}) \\ \beta_! \uparrow \downarrow \beta^* & & \alpha_! \uparrow \downarrow \alpha^* \\ \text{Alg}_{\mathcal{A}+\mathcal{A}}(\mathbb{V}) & \begin{array}{c} \xrightarrow{\psi_!} \\ \perp \\ \xleftarrow{\psi^*} \end{array} & \text{Alg}_{\mathcal{P}}(\mathbb{V}) \end{array}$$

According to Theorem (6.3.4), for each $(X, K) \in \text{Alg}_{\mathcal{P}+\mathcal{A}}$ we have a retraction of $\mathcal{A} + \mathcal{A}$ -algebras:

$$\gamma^* \phi_!(X, K) \rightarrow \psi^* \psi_! \beta^*(X, K) \rightarrow \gamma^* \phi_!(X, K),$$

which by application of Lemmas 7.3.2 and 7.4.1 proves the result. \square

Example 7.4.3. To illustrate Proposition 7.4.2 let's see what it tells us in case of *Ass*. The nonsymmetric convolution of *Ass* is just the tensor product in \mathbb{V} . According to [BB17, Section 9.2] the underlying object of the coproduct of monoids X and a free monoid on K is given by

$$\coprod_{k \geq 0} U(X) \otimes (K \otimes U(X))^{\otimes k} \subset \coprod_{p, q \geq 0, \sigma \in \text{Sh}_{p, q}} \sigma(\odot_P^{p+q})(\underbrace{U(X), \dots, U(X)}_p, \underbrace{K, \dots, K}_q)$$

The retraction on a summand $\sigma(\odot_P^{p+q})(\underbrace{U(X), \dots, U(X)}_p, \underbrace{K, \dots, K}_q)$ multiplies any consecutive string of $U(X)$ s between two K s using the multiplication in X and introduces a copy of $U(X)$ between any two consecutive K s using the unit in X . For instance:

$$\begin{aligned} K \otimes K \otimes U(X) \otimes U(X) \otimes U(X) \otimes K &\cong I \otimes K \otimes I \otimes K \otimes (U(X) \otimes U(X) \otimes U(X)) \otimes K \otimes I \rightarrow \\ &\rightarrow U(X) \otimes K \otimes U(X) \otimes K \otimes U(X) \otimes K \otimes U(X). \end{aligned}$$

8. TRANSFER THEOREM

8.1. Convolution and Transfer of semimodel structures. For the reader's convenience we recall standard material about Quillen functors of many variables. Let C_1, \dots, C_k, C be a list of cocomplete categories. Let $T : C_1 \times \dots \times C_k \rightarrow C$ be a functor. Let $f_1 : K_1 \rightarrow L_1, \dots, f_k : K_k \rightarrow L_k$ be morphisms in C_1, \dots, C_k correspondingly. The functor T generates a commutative k -cube of morphisms in

C as follows. The k -cube \mathbf{I}^k as a poset has vertices the subsets of the set $\{1, \dots, k\}$ ordered by inclusion. Let $S \subset \{1, \dots, k\}$ be such a vertex. We put

$$T(S) = T(X_1, \dots, X_k),$$

where $X_i = K_i$ if $i \notin S$ and $X_i = L_i$ if $i \in S$. For an inclusion $j : P \subset S$ we associate the morphism

$$(8.1.1) \quad T(j) = T(h_1, \dots, h_k)$$

where $h_i = f_i$ if $i \notin P$ but $i \in S$ and $h_i = id$ otherwise.

Let also \mathbf{I}_\circ^k be a punctured k -cube $\mathbf{I}^k \setminus \{1, \dots, k\}$.

Definition 8.1.1. Let $T : C_1 \times \dots \times C_k \rightarrow C$ be a functor. The corner map $f_1 \square f_2 \square \dots \square f_k$ is the morphism

$$\text{colim}_{\mathbf{I}_\circ^k} T(S) \rightarrow T(L_1, \dots, L_k).$$

Remark 8.1.2. Let (C, \otimes, I) be a monoidal category such that \otimes preserves colimits in both variables. Let $T(X, Y) = X \otimes Y$. The functor $-\square- : Arr(C) \times Arr(C) \rightarrow Arr(C)$ is the tensor part of a monoidal structure on the category $Arr(C)$ of arrows of C [Mur11]. It is Day's convolution product generated by the monoidal structure on the poset $0 < 1$, whose unit object is 1 and whose tensor product is $\max(-, -)$. More generally, if the sequence of functors $T_k : C^k \rightarrow C, k \geq 0$ is a cocomplete lax-monoidal structure on C , then the sequence of functors $\square^k, k \geq 0$ provides a cocomplete lax-monoidal structure on $Arr(C)$ [DS03b].

Now assume that the categories $C_i, 1 \leq i \leq k$ and C are semimodel categories.

Definition 8.1.3. We call $T : C_1 \times \dots \times C_k \rightarrow C$ *left Quillen* if it preserves colimits in each variable and $f_1 \square f_2 \square \dots \square f_k$ is a cofibration whenever all f_i are cofibrations with cofibrant domains and, moreover, the morphism $f_1 \square f_2 \square \dots \square f_k$ is trivial cofibration provided one of f_i is a trivial cofibration.

Remark 8.1.4. For $k = 1$ this definition states simply that T preserves cofibrations and trivial cofibrations with cofibrant domains. It is interesting that this definition also makes sense for $k = 0$. In this case we have an empty product of categories so the functor T is just a functor $T : \mathbf{1} \rightarrow C$ i.e. an object $T(\mathbf{1})$ of C . Here $\mathbf{1}$ is the terminal category. The 0-cube is a one point poset and the punctured cube is empty. Therefore, $T : \mathbf{1} \rightarrow C$ is left Quillen if and only if $T(\mathbf{1})$ is cofibrant.

Definition 8.1.5. We will call a Σ -free substitute (P, A) a *left Quillen substitute* with respect to a semimodel model structure on $[A, \mathbb{V}]$ if its nonsymmetric convolution forms a sequence of left Quillen functors on $[A, \mathbb{V}]$.

Example 8.1.6. The substitute for the operad $\mathcal{E} = Ass$ is left Quillen with respect to a semimodel structure on $\mathbb{V} = [1, \mathbb{V}]$ if and only if \mathbb{V} is a monoidal semimodel category.

Theorem 8.1.7. *Let (P, A) be a unary tame substitute and let (\mathbb{V}, \otimes, I) be a cocomplete symmetric monoidal category. Assume that the category $[A, \mathbb{V}]$ is equipped with a cofibrantly generated semimodel structure. Then $\text{Alg}_P(\mathbb{V})$ admits a semimodel structure transferred from $[A, \mathbb{V}]$ provided (P, A) is left Quillen with respect to $[A, \mathbb{V}]$.*

Moreover, the forgetful functor $U : \text{Alg}_P \rightarrow [A, \mathbb{V}]$ preserves cofibrant objects as well as cofibrations between cofibrant objects.

Notice that according to the Remarks 5.1.4 and 8.1.4 the underlying object of the initial P -algebra is cofibrant in $[A, \mathbb{V}]$. This enables us to use the transfer techniques described in Theorem 2.2.2 and follow the idea of the proof of Transfer Theorem for algebras over tame polynomial monad from [BB17] but we need some modification of the techniques from the loc. cit. to capture the action of unary operations of the substitute.

8.2. Classifier for free algebra extensions. Let (P, A) be a substitute in Set . Let $\mathbb{P}_{f,g}$ be the category whose objects are quintuples (X, K, L, g, f) , where X is a P -algebra, K, L are objects in $[A, \text{Set}]$ and $g : K \rightarrow \eta^*(X)$, $f : K \rightarrow L$ are morphisms in $[A, \text{Set}]$. There is an obvious forgetful functor

$$\mathcal{U}_{f,g} : \mathbb{P}_{f,g} \rightarrow [A_0, \text{Set}] \times [A_0, \text{Set}] \times [A_0, \text{Set}],$$

taking the quintuple (X, K, L, f, g) in $\mathbb{P}_{f,g}$ to the triple $\eta^*(X), i^*(K), i^*(L)$, where $i : A_0 \rightarrow A$ is the inclusion of the maximal discrete subcategory of A , and η_0 is the composite of the unit η and i as usual.

Proposition 8.2.1. (i) *The functor $\mathcal{U}_{f,g}$ is monadic and the induced monad $\mathcal{P}_{f,g}$ is polynomial;*
(ii) *There is a commutative square of adjunctions*

$$\begin{array}{ccc} \mathbb{P}_{f,g} & \begin{array}{c} \xrightarrow{L_P} \\ \perp \\ \xleftarrow{R_P} \end{array} & \text{Alg}_P \\ \begin{array}{c} \uparrow F_{f,g} \\ \downarrow U_{f,g} \end{array} & & \begin{array}{c} \uparrow (\eta_0)_! \\ \downarrow \eta_0^* \end{array} \\ [A_0, \text{Set}] \times [A_0, \text{Set}] \times [A_0, \text{Set}] & \begin{array}{c} \xrightarrow{-\sqcup-} \\ \perp \\ \xleftarrow{\Delta} \end{array} & [A_0, \text{Set}] \end{array}$$

in which Δ is the diagonal and R_P is given by

$$R_P(Y) = (Y, \eta^*(Y), \eta^*(Y), id_{\eta^*(Y)}, id_{\eta^*(Y)}).$$

(iii) *The left adjoint L_P to R_P is given by the following pushout in Alg_P :*

$$\begin{array}{ccc} \eta_!(K) & \xrightarrow{\eta_!(f)} & \eta_!(L) \\ \hat{g} \downarrow & & \downarrow \\ X & \longrightarrow & L_P(X, K, L, g, f) \end{array}$$

in which \hat{g} is the mate of g .

Proof. The proof is completely analogous to the proof of Proposition 7.2 in [BB17] \square

We will need an explicit description of the classifier $\mathcal{P}^{\mathcal{P}_{f,g}}$. It coincides almost verbatim to the description of $T^{T_{f,g}}$ given in [BB17, Section 7.4]. So, we recall it briefly.

The objects of $\mathcal{P}^{\mathcal{P}_{f,g}}$ are corollas decorated by the elements of $B = \mathcal{P}(1)$ with incoming edges coloured by one of the three colours X, K, L :

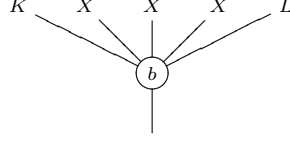

(8.2.1)

These incoming edges will be called X -edges, K -edges or L -edges accordingly.

Morphisms of $\mathcal{P}^{\mathcal{P}_{f,g}}$ can be described in terms of generators and relations. There are three types of generators. First, we have the generators coming from the P -algebra structure on X -coloured edges and unary operation on K and L edges corresponding to morphisms of A . The relations between these generators witness the relations between P_0 -operations. We will call these generators X -generators.

The next type of generators corresponds to the morphism $f : K \rightarrow L$. Such a generator simply replaces a K -edge with an L -edge in the corolla. Generators of this kind will be called F -generators.

Finally, we have generators corresponding to $g : K \rightarrow \eta^*(X)$. Such a generator replaces a K -edge with an X -edge. Generators of this kind will be called G -generators.

An important property for us is that every span $b \xleftarrow{\phi} a \xrightarrow{\psi} a'$ in which ϕ is an F -generator (resp. G -generator) and ψ is an X -generator, extends uniquely to a commutative square

$$(8.2.2) \quad \begin{array}{ccc} a & \xrightarrow{\psi} & a' \\ \phi \downarrow & & \downarrow \phi' \\ b & \xrightarrow{\psi'} & b' \end{array}$$

in which ϕ' is an F -generator (resp. G -generator) and ψ' is an X -generator.

We now proceed like in Section 7 of [BB17] and introduce other monads associated to (P, A) .

Let \mathbb{P}_f be the category whose objects are quadruples (X, K, L, f) , where X is a P -algebra, K, L are objects in $[A, \text{Set}]$ and $f : K \rightarrow L$ is a morphism in $[A, \text{Set}]$.

Let \mathbb{P}_g be the category whose objects are quadruples (X, K, L, g) , where X is a P -algebra, K, L are objects in $[A, \text{Set}]$ and $g : K \rightarrow \eta^*(X)$ is a morphism in $[A, \text{Set}]$.

The obvious forgetful functors $U_f : \mathbb{P}_f \rightarrow [A_0, \text{Set}] \times [A_0, \text{Set}] \times [A_0, \text{Set}]$ and $U_g : \mathbb{P}_g \rightarrow [A_0, \text{Set}] \times [A_0, \text{Set}] \times [A_0, \text{Set}]$ are monadic, yielding monads \mathcal{P}_f and \mathcal{P}_g for which there are propositions analogous to Proposition 8.2.1. We leave the details to the reader.

We put $\mathcal{P} + 2\mathcal{A} = (\mathcal{P} + \mathcal{A}) + \mathcal{A}$ which is also a polynomial monad on $[A_0, \text{Set}] \times [A_0, \text{Set}] \times [A_0, \text{Set}]$ as are $\mathcal{P}_{f,g}$, \mathcal{P}_f and \mathcal{P}_g .

There is a commutative square of forgetful functors over $[A_0, \text{Set}] \times [A_0, \text{Set}] \times [A_0, \text{Set}]$

$$(8.2.3) \quad \begin{array}{ccc} \mathbb{P}_{f,g} & \longrightarrow & \mathbb{P}_f \\ \downarrow & & \downarrow \\ \mathbb{P}_g & \longrightarrow & \text{Alg}_P \times [A, \text{Set}] \times [A, \text{Set}] \end{array}$$

and all four forgetful functors have left adjoints so that we get a commutative square of monad morphisms going in the opposite direction and augmented over P_0 via cartesian natural transformations:

$$(8.2.4) \quad \begin{array}{ccc} \mathcal{P}_{f,g} & \longleftarrow & \mathcal{P}_f \\ \uparrow & & \uparrow \\ \mathcal{P}_g & \longleftarrow & \mathcal{P} + 2\mathcal{A} \end{array}$$

We thus obtain a commutative square of categorical P -algebra maps of the corresponding classifiers, which enables us to analyse the category structure of $\mathcal{P}^{\mathcal{P}_{f,g}}$.

$$(8.2.5) \quad \begin{array}{ccc} \mathcal{P}^{\mathcal{P}_{f,g}} & \longleftarrow & \mathcal{P}^{\mathcal{P}_f} \\ \uparrow & & \uparrow \\ \mathcal{P}^{\mathcal{P}_g} & \longleftarrow & \mathcal{P}^{\mathcal{P} + 2\mathcal{A}} \end{array}$$

Finally, we have a map of monads over \mathcal{P} :

$$\mathcal{P} + \mathcal{A} \rightarrow \mathcal{P} + 2\mathcal{A}$$

which is the identity on \mathcal{P} and sends \mathcal{A} to the second copy of \mathcal{A} in $(\mathcal{P} + \mathcal{A}) + \mathcal{A}$. Thus we have a map of classifiers:

$$\mathcal{P}^{\mathcal{P} + \mathcal{A}} \rightarrow \mathcal{P}^{\mathcal{P} + 2\mathcal{A}}.$$

Lemma 8.2.2. (1) *The classifiers $\mathcal{P}^{\mathcal{P}_{f,g}}, \mathcal{P}^{\mathcal{P}_f}, \mathcal{P}^{\mathcal{P}_g}, \mathcal{P}^{\mathcal{P} + 2\mathcal{A}}$ all have the same object-set, and the diagram of (8.2.5) identifies $\mathcal{P}^{\mathcal{P}_f}, \mathcal{P}^{\mathcal{P}_g}$ with subcategories of $\mathcal{P}^{\mathcal{P}_{f,g}}$ which intersect in $\mathcal{P}^{\mathcal{P} + 2\mathcal{A}}$ and which generate $\mathcal{P}^{\mathcal{P}_{f,g}}$ as a category.*

(2) *The composite*

$$\mathcal{P}^{\mathcal{P} + \mathcal{A}} \rightarrow \mathcal{P}^{\mathcal{P} + 2\mathcal{A}} \rightarrow \mathcal{P}^{\mathcal{P}_f}$$

has a left adjoint p such that the counit of the adjunction is the identity. Thus $\mathcal{P}^{\mathcal{P} + \mathcal{A}}$ is a reflective subcategory of $\mathcal{P}^{\mathcal{P}_f}$.

(3) *The composite*

$$\mathcal{P}^{\mathcal{P} + \mathcal{A}} \rightarrow \mathcal{P}^{\mathcal{P} + 2\mathcal{A}} \rightarrow \mathcal{P}^{\mathcal{P}_g}$$

has a left adjoint r such that the counit of the adjunction is the identity. Thus $\mathcal{P}^{\mathcal{P} + \mathcal{A}}$ is a reflective subcategory of $\mathcal{P}^{\mathcal{P}_g}$.

Proof. The proof of the first point of the lemma is completely analogous to the proof of [BB17, Lemma 7.3].

For the second point observe that there is a map of monads $k : \mathcal{P}_g \rightarrow \mathcal{P} + \mathcal{A}$ over \mathcal{P} . The corresponding restriction functor $k^* : \text{Alg}_{\mathcal{P} + \mathcal{A}} \rightarrow \text{Alg}_{\mathcal{P}_g}$ sends a pair (X, L) to the quadruple (X, \emptyset, L, ι) . Here, \emptyset is the initial object in $[A, \text{Set}]$ and $\iota : \emptyset \rightarrow U_P(X)$ is the unique morphism. The map k induces the reflection $p : \mathcal{P}^{\mathcal{P}_g} \rightarrow \mathcal{P}^{\mathcal{P} + \mathcal{A}}$.

Explicitly this functor takes an object of $\mathcal{P}^{\mathcal{P}^g}$ and replaces all K -edges by X -edges. The unit of this adjunction is generated by applying G -generators to all K -edges in the object.

For the third point we have a similar map of monads $l : \mathcal{P}_f \rightarrow \mathcal{P} + \mathcal{A}$ over \mathcal{P} . The restriction functor $l^* : \text{Alg}_{\mathcal{P}+\mathcal{A}} \rightarrow \text{Alg}_{\mathcal{P}_f}$ sends a pair (X, L) to the quadruple (X, \emptyset, L, ι) , where $\iota : \emptyset \rightarrow L$ is the unique morphism again. The map l induces the reflection $r : \mathcal{P}^{\mathcal{P}_f} \rightarrow \mathcal{P}^{\mathcal{P}+\mathcal{A}}$. This reflection r on an object from $\mathcal{P}^{\mathcal{P}_f}$ replaces all K -edges by L -edges and the unit is obtained by iterated application of F -generators. \square

8.3. Canonical filtration. To shorten notations we put $\mathbf{p} = \mathcal{P}^{\mathcal{P}^{f.g}}$. We say that an object a of \mathbf{p} is of type (p, q) if a contains exactly p K -edges and q L -edges, and we call $p + q$ the *degree* of a . Let $k \geq 1$. We define:

- $\mathbf{p}^{(k)}$ to be the full subcategory of \mathbf{p} spanned by all objects of degree $\leq k$;
- $\mathbf{L}^{(k)}$ to be a full subcategory of $\mathcal{P}^{\mathcal{P}+\mathcal{A}} \subset \mathcal{P}^{\mathcal{P}+2\mathcal{A}} \subset \mathbf{p}$ spanned by all objects of degree $\leq k$;
- $\mathbf{w}^{(k)}$ to be the full subcategory of \mathbf{p} spanned by all objects of degree exactly k ;
- $\mathbf{q}^{(k)}$ to be the full subcategory of $\mathbf{w}^{(k)}$ spanned by all objects of type $(p, k - p)$ such that $p \neq 0$;
- $\mathbf{l}^{(k)}$ to be the full subcategory of $\mathbf{w}^{(k)}$ spanned by all objects of type $(0, k)$;
- $\overline{\mathbf{q}}^{(k)}$ to be the full subcategory of $\mathbf{p}^{(k)}$ spanned by the objects not contained in $\mathbf{l}^{(k)}$.

Proposition 8.3.1. *For any functor $\mathbf{X} : \mathcal{P}^{\mathcal{P}^{f.g}} \rightarrow \mathbb{V}$, the colimit of \mathbf{X} is a sequential colimit of pushouts in \mathbb{V} .*

More precisely, for $S_k = \text{colim}_{\mathbf{p}^{(k)}} \mathbf{X}|_{\mathbf{p}^{(k)}}$, we get

$$S = \text{colim}_{\mathbf{p}} \mathbf{X} \cong \text{colim}_k S_k,$$

where the canonical map $S_{k-1} \rightarrow S_k$ is part of the following pushout square in \mathcal{E}

$$(8.3.1) \quad \begin{array}{ccc} Q_k & \xrightarrow{w_k} & L_k \\ \alpha_k \downarrow & \lrcorner & \downarrow \\ S_{k-1} & \longrightarrow & S_k \end{array}$$

in which Q_k (resp. L_k) is the colimit of the restriction of \mathbf{X} to $\mathbf{q}^{(k)}$ (resp. $\mathbf{l}^{(k)}$).

Proof. First, observe that $\mathbf{p}^{(k-1)}$ is a reflective subcategory of $\overline{\mathbf{q}}^{(k)}$. The reflection is constructed as follows. We have the restriction of r from Lemma 8.2.2 to $\overline{\mathbf{q}}^{(k)}$ with the target category $\mathbf{L}^{(k)}$. Composing it with the inclusion to $\mathbf{p}^{(k)}$ we have a functor $r' : \overline{\mathbf{q}}^{(k)} \rightarrow \mathbf{p}^{(k)}$. Observe, however, that the objects of $\overline{\mathbf{q}}^{(k)}$ either have all edges with X colour or contain at least one K -edge. So application of a G -generator produces an object from $\mathbf{p}^{(k-1)}$ which means that we can factorise r' through $\mathbf{p}^{(k-1)}$ and so we have a reflection $r'' : \overline{\mathbf{q}}^{(k)} \rightarrow \mathbf{p}^{(k-1)}$.

Similarly, the category $\mathbf{l}^{(k)}$ is also a reflective subcategory of $\mathbf{w}^{(k)}$ by the restriction of the reflection p from Lemma 8.2.2.

Consider the following diagram of categories where the central square commutes:

$$(8.3.2) \quad \begin{array}{ccccc} & & \mathbf{q}^{(k)} & \longrightarrow & \mathbf{w}^{(k)} & \longleftarrow & \mathbf{l}^{(k)} \\ & & \downarrow & & \downarrow & & \\ \mathbf{p}^{(k-1)} & \longrightarrow & \mathbf{q}^{(k)} & \longrightarrow & \mathbf{p}^{(k)} & & \end{array}$$

Restricting X to this subcategory and taking colimits we obtain a commutative diagram like (8.3.1). We only need to know that this is a pushout diagram in \mathbb{V} .

A closer inspection of the central square (8.3.2) reveals that it is a categorical pushout of a special kind: the category $\mathbf{p}^{(k)}$ is obtained as the set-theoretical union of the categories $\mathbf{q}^{(k)}$ and $\mathbf{w}^{(k)}$ along their common intersection $\mathbf{q}^{(k)}$. Indeed, away from this intersection, there are no morphisms in $\mathbf{p}^{(k)}$ between objects of $\mathbf{q}^{(k)}$ and objects of $\mathbf{w}^{(k)}$. By Lemma 7.13 from [BB17], this implies that (8.3.1) is a pushout square in \mathbb{V} . \square

8.4. End of proof of Transfer Theorem. We are ready to complete the proof of the Theorem 8.1.7.

Proof. If (P, A) is unary tame, then the classifier $\mathcal{P}^{\mathcal{P}+2\mathcal{A}}$ also contains a final subcategory of unary morphisms, which is a pullback

$$\begin{array}{ccc} \mathbf{t} & \longrightarrow & \mathcal{P}^{\mathcal{P}+2\mathcal{A}} \\ \downarrow & & \downarrow \\ \tau & \longrightarrow & \mathcal{P}^{\mathcal{P}+\mathcal{A}} \end{array}$$

In this pullback τ is the final subcategory from the definition of (unary) tameness, the morphism $D : \mathcal{P}^{\mathcal{P}+2\mathcal{A}} \rightarrow \mathcal{P}^{\mathcal{P}+\mathcal{A}}$ is induced by the folding map of polynomial monads $\mathcal{A} + \mathcal{A} \rightarrow \mathcal{A}$. The fact that \mathbf{t} is final can be proved by a direct calculation.

Consider the composite $\mathbf{t} \cap \mathbf{q}^{(k)} \hookrightarrow \mathcal{P}^{\mathcal{P}+2\mathcal{A}} \cap \mathbf{q}^{(k)} \hookrightarrow \mathbf{q}^{(k)}$. One can factorise this composite as follows:

$$\mathbf{t} \cap \mathbf{q}^{(k)} \xrightarrow{H} \mathbf{t}^{(k)} \xrightarrow{E} \mathbf{q}^{(k)}$$

where $\mathbf{t}^{(k)}$ is obtained from $\mathbf{t} \cap \mathbf{q}^{(k)}$ by adding F -generators.

We claim that $\mathbf{t}^{(k)}$ is a final subcategory of $\mathbf{q}^{(k)}$. The proof is very much the same as in [BB17, Lemma 7.6].

Let $3\mathcal{A} = \mathcal{A} + \mathcal{A} + \mathcal{A}$ be the obvious polynomial monad over \mathcal{P} . Similar to the proof of Proposition 7.4.2 we have the following inclusions of categories:

$$\mathbf{t} \hookrightarrow \mathcal{P}^{3\mathcal{A}} \hookrightarrow \mathcal{P}^{\mathcal{P}+2\mathcal{A}}.$$

So we get

$$\mathbf{t} \cap \mathbf{q}^{(k)} \hookrightarrow \mathcal{P}^{3\mathcal{A}} \cap \mathbf{q}^{(k)} \hookrightarrow \mathcal{P}^{\mathcal{P}+2\mathcal{A}} \cap \mathbf{q}^{(k)} \hookrightarrow \mathbf{q}^{(k)}.$$

Let $\mathbf{u}^{(k)}$ be the category obtained from $\mathcal{P}^{3\mathcal{A}} \cap \mathbf{q}^{(k)}$ by adding F -generators as for $\mathbf{t}^{(k)}$. We then have another inclusion of categories whose composite is a final inclusion:

$$\mathbf{t}^{(k)} \hookrightarrow \mathbf{u}^{(k)} \hookrightarrow \mathbf{q}^{(k)}.$$

Now, given an algebra (X, K, L, f, g) of $P_{f,g}$ We see that the colimit Q_k of the restriction of $\mathbf{X} = (X, \widetilde{K}, L, f, g)$ over $\mathbf{q}^{(k)}$ is naturally a retract of the colimit of its restriction on $\mathbf{u}^{(k)}$.

To analyze the structure of this colimit over $\mathbf{u}^{(k)}$ we first observe like in Proposition 7.4.2 that the colimit of the restriction of \mathbf{X} on $\mathcal{P}^{3A} \cap \mathbf{q}^{(k)}$ is given by the formula

$$\coprod_{p+q=k, p>0, s \geq 0, \sigma \in Sh_{s,p,q}} \sigma(\odot_P^{s+p+q})(\underbrace{\eta^*(X), \dots, \eta^*(X)}_s, \underbrace{K, \dots, K}_p, \underbrace{L, \dots, L}_q).$$

The colimit of \mathbf{X} over $\mathbf{u}^{(k)}$ is obtained from this coproduct by taking further colimit. The additional morphisms which appear here are morphisms induced by $f : K \rightarrow L$ and, therefore, this colimit is a coproduct of colimits over punctured cubes for the nonsymmetric convolution \odot_P .

We then see that the map $w_k : Q_k \rightarrow L_k$ is a retract of a coproduct of corner maps for \odot_P^k , $k \geq 0$ of the form $\sigma(\square^n)(X, \dots, X, f, \dots, f)$ for some (s, k) -shuffles σ , a trivial cofibration with cofibrant domain $f : K \rightarrow L$ and a cofibrant presheaf X . Hence, w_k is a trivial cofibration itself and so by Proposition 8.3.1 the morphism $p : X \rightarrow S$ in 2.2.2 is a weak equivalence as well. We finished the proof. \square

Remark 8.4.1. Notice that the conditions of the Transfer Theorem concern the properties of nonsymmetric convolution of (P, A) on $[A, \mathbb{V}]$ and we don't even assume that \mathbb{V} itself is a monoidal model category.

8.5. Beck-Chevalley morphisms of substitutes.

Definition 8.5.1. Let $(f, g) : (P, A) \rightarrow (Q, B)$ be a map of substitutes. We call the morphism Beck-Chevalley if the following square is a Beck-Chevalley square:

$$\begin{array}{ccc} \text{Alg}_P(\mathbb{V}) & \begin{array}{c} \xrightarrow{f_!} \\ \perp \\ \xleftarrow{f^*} \end{array} & \text{Alg}_Q(\mathbb{V}) \\ (\eta_P)_! \uparrow \downarrow (\eta_P)^* & & (\eta_Q)_! \uparrow \downarrow (\eta_Q)^* \\ [A, \mathbb{V}] & \begin{array}{c} \xrightarrow{g_!} \\ \perp \\ \xleftarrow{g^*} \end{array} & [B, \mathbb{V}] \end{array}$$

Definition 8.5.2. Let (P, A) be a substitute and the categories $[A, \mathbb{V}]$ and $\text{Alg}_P(\mathbb{V})$ are equipped with semimodel structures in such a way that the pair $(\eta_P)^* \dashv (\eta_P)_!$ is a Quillen adjunction. In this case, we will say the (P, A) is derivable (with respect to fixed semimodel structures). A morphism of derivable substitutes is a morphism of substitutes for which the commutative square of adjunctions is a square of Quillen adjunctions.

Definition 8.5.3. We call a morphism of derivable substitutes $(f, g) : (P, A) \rightarrow (Q, B)$ a homotopy Beck-Chevalley morphism if the square above (8.5.1) is a homotopy Beck-Chevalley square.

Proposition 8.5.4. *The class of Beck-Chevalley morphisms satisfies the two out of three property. The same is true for homotopy Beck-Chevalley morphisms of derivable substitutes.*

Proof. It is not hard to prove that the Beck-Chevalley transformation (4.1.2) for a horizontal pasting of two Beck-Chevalley square is obtained as a pasting of Beck-Chevalley transformations of each squares. Hence the result. \square

Theorem 8.5.5. *Let $(f, g) : (P, A) \rightarrow (Q, B)$ be a Beck-Chevalley morphism between unary tame left Quillen substitutes for which the semimodel structures on $\text{Alg}_P(\mathbb{V})$ and $\text{Alg}_Q(\mathbb{V})$ are transferred from some cofibrantly generated semimodel structures on $[A, \mathbb{V}]$ and $[B, \mathbb{V}]$. If $g_! \dashv g^*$ is a pair of Quillen equivalences then $f_! \dashv f^*$ is also a pair of Quillen equivalences.*

Proof. Immediate from Corollary 4.2.3. □

Part 3. Localisation of algebras of substitutes

In this part we study a particular but very important case of our Transfer Theorem for $\text{Alg}_P(\mathbb{V})$, when the model structure on $[A, \mathbb{V}]$ is obtained as a localisation of the projective model structure $[A, \mathbb{V}]_{\text{proj}}$.

9. LOCALISATION OF PRESHEAF CATEGORIES

9.1. Fundamental localisers. We recall some definitions and results from the homotopy theory of small categories founded by Grothendieck.

Let \mathbb{W} be a class of functors between small categories.

Definition 9.1.1. The class \mathbb{W} is called fundamental localiser if it satisfies the following conditions:

- (1) \mathbb{W} contains all identities;
- (2) \mathbb{W} satisfies the two out of three property;
- (3) If $i : A \rightarrow B$ has a retraction $r : B \rightarrow A$ and $r \cdot i : B \rightarrow B$ is in \mathbb{W} then i is in \mathbb{W} ;
- (4) If A is a small category with a terminal object then $A \rightarrow \mathbf{1}$ is in \mathbb{W} ;
- (5) If in a commutative triangle of functors between small categories

$$\begin{array}{ccc} A & \xrightarrow{u} & B \\ & \searrow v & \swarrow w \\ & & C \end{array}$$

the functor $u/c : A/c \rightarrow B/c$ is in \mathbb{W} for each object $c \in C$ then u is in \mathbb{W} .

Definition 9.1.2. A class of functors between small categories is called a weak fundamental localiser if it satisfies properties (1)-(4) above and property (5) for $w = \text{id} : B \rightarrow B$.

For a (weak) fundamental localiser \mathbb{W} we call its elements \mathbb{W} -equivalences. A small category A is called \mathbb{W} -aspherical if the unique functor $A \rightarrow \mathbf{1}$ is in \mathbb{W} . A functor $u : A \rightarrow B$ is \mathbb{W} -aspherical if for all $b \in B$ the category u/b is \mathbb{W} -aspherical. Any \mathbb{W} -aspherical functor is a \mathbb{W} -equivalence.

Remark 9.1.3. The condition (5) of the definition above can be formulated as follows. If the morphism of presheaves $C^A \rightarrow C^B$ in Cat induced by (5) is the fiberwise \mathbb{W} -equivalence then u is a \mathbb{W} -equivalence.

There is a notion of proper fundamental localiser ([Cis06, Definition 4.3.21] which we don't reproduce here. Instead we recall that \mathbb{W} is a proper fundamental localiser if and only if there exists a set \mathcal{S} of small categories which \mathbb{W} makes trivial, in the sense that for any $A \in \mathcal{S}$ the functor $A \rightarrow \mathbf{1}$ is in \mathbb{W} , and \mathbb{W} is minimal with this property [Cis06, Theorem 6.1.11]. We use notation $\mathbb{W} = \mathbb{W}(\mathcal{S})$ in this case.

Example 9.1.4. Let \mathcal{S} contain only one element: the arrow category $0 \rightarrow 1$. Then $\mathbb{W}(\mathcal{S})$ is equal to \mathbb{W}_∞ the class of functors whose nerve is a weak equivalence. This is easy to see because the arrow category has a terminal object and so is trivialised by every fundamental localiser. But \mathbb{W}_∞ is the minimal fundamental localiser [Cis06, Corollary 4.2.19].

Example 9.1.5. Let \mathcal{S} consist of a unique element S^{k+1} , where S^{k+1} is a small category which has homotopy type of $(k+1)$ -sphere. For example, one can take $S^{k+1} = \Delta/\partial(\Delta_{k+2})$ as in [Cis06, Section 9.2].

Then $\mathbb{W}(\mathcal{S})$ -equivalences are k -equivalences, that is, functors inducing isomorphisms of homotopy groups up to k (including k) [Cis06, Corollaire 9.2.15]. The $\mathbb{W}(\mathcal{S})$ -aspherical categories are exactly the k -connected categories. Following [Cis06] we will denote the localiser $\mathbb{W}(\mathcal{S})$ simply \mathbb{W}_k .

The localiser \mathbb{W}_0 contains functors that induce isomorphism on sets of connected components, and \mathbb{W}_0 -aspherical categories are connected categories. Without loss of generality, we can assume that \mathbb{W}_0 contains all other fundamental localisers that we consider in this paper [Cis06, Proposition 9.3.2].

9.2. Locally constant presheaves. Let A be a small category and let \mathbb{V} be a model category. Let $Ho[A, \mathbb{V}]$ be the localisation of the category of covariant presheaves $[A, \mathbb{V}]$ with respect to levelwise weak equivalences.

Definition 9.2.1. A presheaf $F : A \rightarrow \mathbb{V}$, is called \mathbb{W} -locally constant if for any \mathbb{W} -aspherical small category A' and any functor $u : A' \rightarrow A$ the presheaf $u^*(F) : A' \rightarrow \mathbb{V}$ is homotopy equivalent in $Ho[A', \mathbb{V}]$ to a constant presheaf.

Let $LC_{\mathbb{W}}[A, \mathbb{V}]$ denote the full subcategory of $Ho[A, \mathbb{V}]$ formed by \mathbb{W} -locally constant presheaves. It is easy to see that any functor $u : A \rightarrow B$ induces a restriction $u^* : LC_{\mathbb{W}}[B, \mathbb{V}] \rightarrow LC_{\mathbb{W}}[A, \mathbb{V}]$.

Call a functor between small categories $u : A \rightarrow B$ a *local \mathbb{W} -equivalence* if $u^* : LC_{\mathbb{W}}[B, \mathbb{V}] \rightarrow LC_{\mathbb{W}}[A, \mathbb{V}]$ is an equivalence of categories for any model category \mathbb{V} . Let us denote by \mathbb{W}_{loc} the class of local \mathbb{W} -equivalences between small categories.

Theorem 9.2.2. (1) *The class \mathbb{W}_{loc} is a weak fundamental localiser.*

(2) *Any \mathbb{W} -aspherical category is also \mathbb{W}_{loc} -aspherical.*

(3) *If \mathbb{W} is proper then $\mathbb{W} \subseteq \mathbb{W}_{loc}$.*

In particular, any \mathbb{W} -equivalence induces an equivalence of homotopy categories of \mathbb{W} -locally constant presheaves.

Proof. The proof of the first statement follows word for word the proof of [Cis09, Theorem 1.3].

The second statement follows from the following tautological argument. Let A be a \mathbb{W} -aspherical category. We have to prove that it is \mathbb{W}_{loc} -aspherical. That is, $A \rightarrow 1$ is a \mathbb{W}_{loc} -equivalence. This amounts to the statement that every \mathbb{W} -locally constant presheaf $F : A \rightarrow \mathbb{V}$ is equivalent to a constant presheaf. But $F : A \rightarrow \mathbb{V}$ is locally constant by definition if, for any \mathbb{W} -aspherical A' and any functor $u : A' \rightarrow A$, the presheaf $u^*(F)$ is equivalent to a constant. We take $u = id$ to finish the proof.

The last statement follows from the fact that \mathbb{W} is proper and from [Cis06, Proposition 6.1.16]. \square

We do not reproduce the argument of Cisinski's Theorem 1.3 from [Cis09] but we want a version of one statement that Cisinski calls the Formal Serre spectral

sequence [Cis09, Proposition 1.24]. For the proof we refer the reader to [Cis09] again.

Definition 9.2.3 ([Cis06], 6.4.1). A functor $u : A \rightarrow B$ between two small categories is called \mathbb{W} -locally constant if for any morphism $b \rightarrow b'$ in B the functor between comma categories $u/b \rightarrow u/b'$ is a \mathbb{W} -equivalence.

Proposition 9.2.4. *If u is \mathbb{W}_{loc} -locally constant then for any model category \mathbb{V} the total left derived functor of $u_!$:*

$$Ho([A, \mathbb{V}]) \rightarrow Ho([B, \mathbb{V}])$$

preserves \mathbb{W} -locally constant presheaves.

Corollary 9.2.5. *If $u^{op} : A^{op} \rightarrow B^{op}$ is \mathbb{W}_{loc} -locally constant then the total right derived functor*

$$u_* : Ho([A, \mathbb{V}]) \rightarrow Ho([B, \mathbb{V}])$$

preserves \mathbb{W} -locally constant presheaves for any model category \mathbb{V} .

Proof. It is enough to apply the previous proposition to \mathbb{V}^{op} and observe that $F : B \rightarrow \mathbb{V}$ is a \mathbb{W} -locally constant presheaf if and only if $F^{op} : B^{op} \rightarrow \mathbb{V}^{op}$ is \mathbb{W} -locally constant. This follows readily from the fact that the class \mathbb{W} is closed under $(-)^{op}$ [Mal05, Proposition 1.1.22]. \square

Remark 9.2.6. Notice that we will need a full model structure on \mathbb{V} in order to have a model structure on \mathbb{V}^{op} . Though this corollary can be proved in greater generality (replacing \mathbb{V} by a derivator) we don't need it in this paper.

Example 9.2.7. Let us explain the connection to the original Cisinski's Theorem 1.3 from [Cis09] more precisely.

Let $\mathbb{W} = \mathbb{W}(\mathcal{S})$. Let us call a presheaf $F : A \rightarrow \mathbb{V}$ from a small category A \mathcal{S} -locally constant if for any $A' \in \mathcal{S}$ and any functor $u : A' \rightarrow A$, the presheaf $u^*(F) : A' \rightarrow \mathbb{V}$ is homotopy equivalent in $Ho[A', \mathbb{V}]$ to a constant presheaf. Let $LC_{\mathcal{S}}[A, \mathbb{V}]$ denote the homotopy category of \mathcal{S} -locally constant presheaves. Call a functor between small categories $u : A \rightarrow B$ a *local \mathcal{S} -equivalence* if $u^* : LC_{\mathcal{S}}[B, \mathbb{V}] \rightarrow LC_{\mathcal{S}}[A, \mathbb{V}]$ is an equivalence of categories for any (semi)-model category \mathbb{V} . Let us denote by $\mathbb{W}_{\mathcal{S}}$ the class of local \mathcal{S} -equivalences between small categories.

Cisinski's argument works in this case too and so $\mathbb{W}_{\mathcal{S}}$ is a weak fundamental localiser.

Let \mathcal{S} as in the Example 9.1.4. Then a presheaf $F : A \rightarrow \mathbb{V}$ is \mathcal{S} -locally constant if and only if $F(\alpha)$ is a weak equivalence in \mathbb{V} for every morphism α in A . That is, it is a locally constant presheaf in the sense of [Cis09].

But \mathbb{W}_{∞} is also the minimal weak fundamental localiser [Cis06, Theorem 6.1.18] so any $\mathbb{W}_{\infty} = \mathbb{W}(\mathcal{S})$ -aspherical category is also $\mathbb{W}_{\mathcal{S}}$ -aspherical. So any Thomason (aka simplicial) weak equivalence between small categories induces an equivalence between homotopy categories of locally constant presheaves in the sense of Cisinski. This is the content of [Cis09, Theorem 1.3].

Unfortunately, while the case $\mathbb{W} = \mathbb{W}_{\infty}$ admits the explicit simple description of the \mathbb{W} -locally constant presheaves given in the Example 9.2.7, we do not know other fundamental localisers where the \mathbb{W} -locally constant presheaves admit such an elementary description.

9.3. Local (semi)model structures on presheaves. We also want to establish an analogue of Cisinski's local model structure on presheaves categories [Cis09, Proposition 2.3]. In contrast with [Cis09] we don't ask for the basis category \mathbb{V} to be left proper. This results to a not necessary full local model structure for presheaves in \mathbb{V} . For a left proper \mathbb{V} we will have full local model structure on presheaves, which is also left proper.

Lemma 9.3.1. *Let \mathbb{V} be a combinatorial model category. Let A be a small category and $e : A \rightarrow 1$ be the unique functor. Then there exists a left Bousfield (semimodel) localisation $[A, \mathbb{V}]_{proj}^0$ of the projective model structure $[A, \mathbb{V}]_{proj}$ such that the induced adjoint pair $e_! \dashv e^*$ is a Quillen equivalence between $[A, \mathbb{V}]_{proj}^0$ and \mathbb{V} . The local objects of this localisation are presheaves $A \rightarrow \mathbb{V}$ which are levelwise fibrant and which are levelwise equivalent to constant presheaves.*

Proof. Since \mathbb{V} is combinatorial, so is $[A, \mathbb{V}]$ with the projective model structure. Following Cisinski [Cis09] we fix a regular cardinal α such that every object of $[A, \mathbb{V}]$ is an α -filtered colimit of a set T of α -small objects, the class of weak equivalences is stable with respect to α -filtered colimits, and there exists a cofibrant resolution functor Q that preserves α -filtered colimits.

We now consider the essentially small set of arrows in $[A, \mathbb{V}]$ of the form:

$$\epsilon : QF \rightarrow e^*e_!(QF),$$

where F is an α -small presheaf in T and ϵ is the unit of the adjunction. Let $[A, \mathbb{V}]_{proj}^0$ be the left Bousfield localisation of $[A, \mathbb{V}]$ with respect to this class of morphisms. As in the proof of [Cis09, Proposition 2.3] we deduce then that for any $F : A \rightarrow \mathbb{V}$ the map

$$\epsilon : QF \rightarrow e^*e_!(QF)$$

is a local weak equivalence, and, hence $\epsilon : F \rightarrow e^*e_!(F)$ is a local weak equivalence for any cofibrant F .

Let now E be a fibrant object in $[A, \mathbb{V}]$ which means that it is levelwise fibrant. It is a local object in the localised category if and only if for any cofibrant F the unit ϵ induces a weak equivalence:

$$[A, \mathbb{V}](\bar{F}, E) \leftarrow [A, \mathbb{V}](\overline{e^*e_!(F)}, E)$$

where \bar{F} is a cosimplicial resolution of the presheaf F in $[A, \mathbb{V}]$. We will show that any local fibrant E is equivalent to a constant presheaf. It is not hard to see that there is a weak equivalence of cosimplicial presheaves:

$$\overline{e^*e_!(F)} \rightarrow e^*e_!(\bar{F})$$

and we have isomorphisms:

$$[A, \mathbb{V}](e^*e_!(\bar{F}), E) \simeq [1, \mathbb{V}](e_!(\bar{F}), e_*(E)) \simeq [A, \mathbb{V}](\bar{F}, e^*e_*(E)).$$

So we have a weak equivalence

$$[A, \mathbb{V}](\bar{F}, E) \leftarrow [A, \mathbb{V}](\bar{F}, e^*e_*(E))$$

induced by counit η of the adjunction $e^* \dashv e_*$, for each cofibrant F . Hence,

$$\eta : e^*e_*(E) \rightarrow E$$

is a levelwise weak equivalence and E is equivalent to the constant presheaf.

It is now obvious that $e_! : [A, \mathbb{V}]_{proj}^0 \rightarrow [1, \mathbb{V}] = \mathbb{V}$ is the left part of a Quillen equivalence.

□

Corollary 9.3.2. *There exists a left Bousfield (semimodel) localisation $[A, \mathbb{V}]_{inj}^0$ of the injective model structure on $[A, \mathbb{V}]$ with respect to the same set of local equivalences such that the local objects are injectively fibrant presheaves equivalent to the constant presheaves. The identity functor*

$$[A, \mathbb{V}]_{inj}^0 \rightarrow [A, \mathbb{V}]_{proj}^0$$

is a right Quillen equivalence.

Moreover, if A is a Reedy category then there is a similar localisation $[A, \mathbb{V}]_{reedy}^0$ of the Reedy model structure and the identity functor gives right Quillen equivalences:

$$[A, \mathbb{V}]_{inj}^0 \rightarrow [A, \mathbb{V}]_{reedy}^0 \rightarrow [A, \mathbb{V}]_{proj}^0$$

Proof. For the injective model structure let us lift the localisation on $[A, \mathbb{V}]_{proj}$ along the Quillen adjunction given by the identity $[A, \mathbb{V}]_{inj} \rightarrow [A, \mathbb{V}]_{proj}$. By Theorem 3.0.4 we have a Quillen equivalence between $[A, \mathbb{V}]_{inj}^0$ and $[A, \mathbb{V}]_{proj}^0$. The same argument works for the Reedy model structure. □

Remark 9.3.3. It seems that we have a Quillen equivalence between $[A, \mathbb{V}]_{inj}^0$ and $[1, \mathbb{V}]$ given by the pair $e^* \dashv e_*$. But neither e_* or $e!$ is a right or left equivalence for localised Reedy model structure in general. But sometimes it is. This subtle property is discussed in [Dug03, RSS01].

We want to use the constructed model structures to induce a model structure on $[A, \mathbb{V}]$ with local objects given by \mathbb{W} -locally constant presheaves.

Theorem 9.3.4. *Let \mathbb{W} be a proper fundamental localiser and \mathbb{V} a combinatorial model category. Then there exist (semimodel) localisations of the projective and injective model structures on $[A, \mathbb{V}]_{proj}^{\mathbb{W}}, [A, \mathbb{V}]_{inj}^{\mathbb{W}}$ such that the local objects are fibrant (in their respective model structures) and \mathbb{W} -locally constant presheaves. If A is Reedy then there exists a localisation $[A, \mathbb{V}]_{reedy}^{\mathbb{W}}$ with similar properties. The identity functors give right Quillen equivalences:*

$$[A, \mathbb{V}]_{inj}^{\mathbb{W}} \rightarrow [A, \mathbb{V}]_{reedy}^{\mathbb{W}} \rightarrow [A, \mathbb{V}]_{proj}^{\mathbb{W}}$$

Proof. Let start from the projective model structure on $[A, \mathbb{V}]$. Let A' be a \mathbb{W} -aspherical category and let $u : A' \rightarrow A$ be a functor. Then consider the following lifting of localisations (where $[A, \mathbb{V}]_{proj}^u$ is defined as the lift of $[A', \mathbb{V}]_{proj}^0$ along u^*):

$$(9.3.1) \quad \begin{array}{ccc} [A, \mathbb{V}]_{proj} & \begin{array}{c} \xrightarrow{id} \\ \xleftarrow{id} \end{array} & [A, \mathbb{V}]_{proj}^u \\ u_! \uparrow \downarrow u^* & & u_! \uparrow \downarrow u^* \\ [A', \mathbb{V}]_{proj} & \begin{array}{c} \xrightarrow{id} \\ \xleftarrow{id} \end{array} & [A', \mathbb{V}]_{proj}^0 \end{array}$$

The local fibrant objects in $[A, \mathbb{V}]_{proj}^u$ are exactly the presheaves that are levelwise fibrant and become equivalent to a constant presheaf after the restriction along u by Theorem 3.0.4.

Recall that there exists a model structure on Cat whose weak equivalences are exactly the functors from \mathbb{W} , whose fibrations are smooth and proper functors and this model structure is proper because \mathbb{W} is proper [Cis06, Theorem 5.3.14]. Let

$\phi : Q \rightarrow A'$ be a trivial fibration in this model structure and A' is a \mathbb{W} -aspherical). We then claim that the localisation $[A, \mathbb{V}]_{proj}^u$ coincides with $[A, \mathbb{V}]_{proj}^{u(\phi)}$. Indeed, we can prove this statement if one can prove that $[A', \mathbb{V}]_{proj}^0$ coincide with $[A', \mathbb{V}]_{proj}^\phi$ because $[A, \mathbb{V}]_{proj}^{u(\phi)}$ can be obtained as two successive liftings but intermediate lifting will be exactly $[A', \mathbb{V}]_{proj}^0$. We then want to prove that the local fibrant objects in $[A', \mathbb{V}]_{proj}^\phi$ and $[A', \mathbb{V}]_{proj}^0$ coincide.

Local objects in $[A', \mathbb{V}]_{proj}^\phi$ are (fibrant) presheaves $F : A' \rightarrow \mathbb{V}$ such that $\phi^*(F)$ are equivalent to constant presheaf given by $\lim_Q(\phi^*(F))$. We have to prove then that F is equivalent to a constant presheaf.

First, observe that ϕ is a final functor. Indeed, for every object $a \in A'$ the natural inclusion functor $Q_a \rightarrow \phi/a$ is from \mathbb{W} because ϕ is proper (this is the definition of \mathbb{W} -properness [Cis06, 5.3.1]), where Q_a is the pullback

$$(9.3.2) \quad \begin{array}{ccc} Q_a & \longrightarrow & 1 \\ \downarrow & & \downarrow a \\ Q & \xrightarrow{\phi} & A' \end{array}$$

Since ϕ is a fibration and $a : 1 \rightarrow A$ is a \mathbb{W} -equivalence we deduce that the left vertical arrow is a weak equivalence and since ϕ is trivial the top arrow is also a weak equivalence. This means that Q_a is at least connected because $\mathbb{W} \subseteq \mathbb{W}_0$. Hence all comma-categories a/ϕ are connected and ϕ is final and $\lim_Q(\phi^*(F)) \simeq \lim_{A'} F$.

We now know that $\phi^*(F)(q) \rightarrow \lim_Q(\phi^*(F))$ is a weak equivalence for each $q \in Q$. But ϕ is surjective on objects and, hence, $F(a) \rightarrow \lim_{A'} F$ is a weak equivalence for each a , therefore, F is equivalent to a constant presheaf.

Now, for each object $a \in A$ let $a : 1 \rightarrow A$ be a functor which picks up a as above. We factorise it as $1 \rightarrow R(a) \rightarrow A$ in the model category above, where $1 \rightarrow R(a)$ is a trivial cofibration (so $R(a)$ is \mathbb{W} -aspherical) and $u_a : R(a) \rightarrow A$ is a fibration. Consider the localisation $[A, \mathbb{V}]_{proj}^{\mathbb{W}}$ obtained by successively lifting the localisations $[R(a), \mathbb{V}]_{proj}^0$ along the functors u_a^* , $a \in A$. (strictly speaking we add to the set of weak equivalences in the categories $[A, \mathbb{V}]_{proj}^{u_a}$, $a \in A$.)

We claim that $[A, \mathbb{V}]_{proj}^{\mathbb{W}}$ the local objects in this category are exactly \mathbb{W} -locally constant fibrant presheaves. We would prove this statement if we can show that for any \mathbb{W} -aspherical A' and any $u : A' \rightarrow A$ the local weak equivalences in $[A, \mathbb{V}]_{proj}^u$ are among the local weak equivalences in $[A, \mathbb{V}]_{proj}^{\mathbb{W}}$.

Let $b : 1 \rightarrow A'$ be a functor and $a : 1 \rightarrow A' \xrightarrow{u} A$. We also can factorise b in the model category on Cat above as $1 \rightarrow Q \xrightarrow{\phi} A'$ as cofibration followed by a trivial fibration. Observe, however, that $1 \rightarrow Q$ is also a trivial cofibration because A' is \mathbb{W} -aspherical.

Consider the commutative square

$$(9.3.3) \quad \begin{array}{ccc} 1 & \longrightarrow & R(a) \\ \downarrow & & \downarrow u_a \\ Q & \xrightarrow{u(\phi)} & A \end{array}$$

We then have a lifting $Q \rightarrow R(a)$ in this square, and this shows that all local weak equivalences from $[A, \mathbb{V}]_{proj}^{u(\phi)}$ (and so from $[A, \mathbb{V}]_{proj}^u$) are among the local weak equivalences from $[A, \mathbb{V}]_{proj}^{u_a}$.

The proofs for injective and Reedy structures are similar. \square

The following Theorem is an analogue of the corresponding statements from Section 2 of [Cis09].

Theorem 9.3.5. *Let $u : A \rightarrow B$ be a functor between two small categories and \mathbb{W} be a proper fundamental localiser. Then*

$$u^* : [B, \mathbb{V}]_{proj}^{\mathbb{W}} \rightarrow [A, \mathbb{V}]_{proj}^{\mathbb{W}}$$

is a right Quillen functor which is a Quillen equivalence if $u \in \mathbb{W}$.

If $u^{op} : A^{op} \rightarrow B^{op}$ is a \mathbb{W} -locally constant functor (see Definition 9.2.3) then

$$u^* : [B, \mathbb{V}]_{inj}^{\mathbb{W}} \rightarrow [A, \mathbb{V}]_{inj}^{\mathbb{W}}$$

is a left Quillen functor which is a Quillen equivalence if $u \in \mathbb{W}$.

The proof is analogous to [Cis09, Propositions 2.6, 2.8].

9.4. Truncated homotopy types. Even though we don't know a satisfactory explicit characterisation of \mathbb{W} -locally constant presheaves the proof above shows that there exists a set of \mathbb{W} -aspherical categories and functors $R(a) \rightarrow A$ which 'detects' \mathbb{W} -locally constant presheaves. Also, under some circumstances we can describe the locally constant presheaves in terms of the \mathbb{W}_∞ -locally constant presheaves.

Recall [Cis06, Corollary 4.2.18] that for every accessible fundamental localiser \mathbb{W} there exists a model structure on simplicial sets such that its cofibrations are monomorphisms and its weak equivalences are exactly maps between simplicial sets such that the induced functor between categories of simplices belongs to \mathbb{W} . We call the fibrant objects in this model category *\mathbb{W} -local simplicial sets* and contractible objects *\mathbb{W} -aspherical simplicial sets*. For $\mathbb{W} = \mathbb{W}_\infty$ the corresponding model structure is just the classical Kan-Quillen model structures.

Definition 9.4.1. Let \mathbb{V} be a model category. We call it *k -truncated* if for any objects X, Y , the mapping space $Map_{\mathbb{V}}(X, Y)$ is a \mathbb{W}_k -local simplicial sets. This means that all homotopy groups of this mapping space vanish for $i > k$ for any choice of a base point.

Theorem 9.4.2. *Let \mathbb{V} be an k -truncated model category. Then the identity functor*

$$[A, \mathbb{V}]_{proj}^{\mathbb{W}_r} \rightarrow [A, \mathbb{V}]_{proj}^{\mathbb{W}_\infty}$$

is a left Quillen equivalence for all $r \geq k + 1$.

Proof. It is enough to prove the theorem for $r = k + 1$. Since \mathbb{W}_∞ is the minimal fundamental localiser every \mathbb{W} -locally constant presheaf is also \mathbb{W}_∞ -locally constant. So, for any \mathbb{W} the identity functor $[A, \mathbb{V}]_{proj}^{\mathbb{W}} \rightarrow [A, \mathbb{V}]_{proj}^{\mathbb{W}_\infty}$ is the left Quillen functor. To prove that this is a Quillen equivalence for $\mathbb{W} = \mathbb{W}_{k+1}$ we have to prove that these categories have the same class of local objects.

It is not hard to see that this amounts to the following statement: every \mathbb{W}_∞ -locally constant presheaf $F \rightarrow \mathbb{V}$ on a \mathbb{W}_{k+1} -aspherical category A' is equivalent to a constant presheaf.

The category A' is connected. Since the homotopy category of W_∞ -locally constant presheaves depends only on the homotopy type of A' we can also think of A' as a monoid [McD79]. Then a presheaf $F' : A' \rightarrow \mathbb{V}$ is just a morphism of monoids $F : A' \rightarrow \mathbb{V}(X, X)$ for some $X \in \mathbb{V}$. Since F is locally constant this functor can be lifted to a map of monoids $F' : \Omega B(A') \rightarrow \text{Map}_{\mathbb{V}}(X, X)$ where $\Omega B(A')$ is the simplicial group whose homotopy type is $\Omega N(A')$ [DK80]. But $N(A')$ is $(k+1)$ -connected, so $\Omega B(A')$ is k -connected but $\text{Map}_{\mathbb{V}}(X, X)$ is k -local. So, F' is homotopic to a constant map as we wanted. \square

10. LOCAL (SEMI)MODEL STRUCTURES ON ALGEBRAS

10.1. Disconnected and constantly disconnected functors and bimodules.

Definition 10.1.1. Let $u : A \rightarrow B$ be a functor between small categories. We call it *fiberwise disconnected* if it is fiberwise disconnected as a morphism of polynomial monads.

This, of course, means that for any $b \in B$, the category u/b has a discrete reflective subcategory or, equivalently, u/b has a terminal object in each connected component.

Definition 10.1.2. And we call $u : A \rightarrow B$ *constantly fiberwise disconnected* if, in addition, u is W_0 -locally constant (i.e. $b \rightarrow b'$ induces an isomorphism $\pi_0(u/b) \rightarrow \pi_0(u/b')$)

As before we are going to shorten our terminology and drop the word ‘fiberwise’ if it does not lead to a confusion.

Proposition 10.1.3. *Let $u : A \rightarrow B$ be a functor such that $u^{op} : A^{op} \rightarrow B^{op}$ is disconnected (i.e. for any $b \in B$ the category b/u has initial object in each connected component.) Then the restriction functor*

$$u^* : [B, \mathbb{V}]_{proj} \rightarrow [A, \mathbb{V}]_{proj}$$

is left Quillen. Moreover, if in addition u^{op} is constantly disconnected (i.e. $b \rightarrow b'$ induces an isomorphism $\pi_0(b/u) \leftarrow \pi_0(b'/u)$), then for any proper fundamental localiser W

$$u^* : [B, \mathbb{V}]_{proj}^W \rightarrow [A, \mathbb{V}]_{proj}^W$$

is also left Quillen.

Proof. Let u_* be the right adjoint to u^* as usual. We need to show that u_* preserves fibrations and trivial fibrations. The value of $u_*(F)(b)$, $b \in B$ is given by

$$\lim_{b/u} \tilde{F} = \prod_{c \in \pi_0(b/u)} \tilde{F}(\bar{c}),$$

where $\tilde{F} : b/u \rightarrow \mathbb{V}$, $\tilde{F}(u(a) \rightarrow b) = F(a)$ and \bar{c} is a chosen initial object in the connected component c of b/a . So, u_* sends any natural transformation $\phi : F \rightarrow G$ to a natural transformation whose components are products of certain components of ϕ . Fibrations and trivial fibrations in projective model structure are defined componentwise. Hence $u_*(\phi)$ is a (trivial) fibration if ϕ is because (trivial) fibrations are closed under products.

To check this for the local model structure, it is enough to see that, under the conditions of the proposition, the functor u^{op} is \mathbb{W}_∞ -locally constant. The result now follows from the Corollary 9.2.5. \square

Definition 10.1.4. Let

$$(10.1.1) \quad F : B^{op} \times A \rightarrow \mathbb{S}et$$

be a bimodule. We will call the bimodule 10.1.1 disconnected (constantly disconnected) if the functor $p^{op} : (\int F)^{op} \rightarrow B^{op}$ is disconnected (constantly disconnected).

Proposition 10.1.5. *For a disconnected bimodule $F : B^{op} \times A \rightarrow \mathbb{S}et$ the functor*

$$p^* \circ \pi_! : [B, \mathbb{V}]_{proj} \rightarrow [\int F, \mathbb{V}]_{proj} \rightarrow [A, \mathbb{V}]_{proj}$$

is a left Quillen functor.

If F is constantly disconnected then for any proper fundamental localiser \mathbb{W} the functor

$$p^* \circ \pi_! : [B, \mathbb{V}]_{proj}^{\mathbb{W}} \rightarrow [A, \mathbb{V}]_{proj}^{\mathbb{W}}$$

is a left Quillen functor.

Proof. The functor p^* is left Quillen by Proposition 10.1.3. The functor $\pi_!$ is always left Quillen for the projective model structure and its localisation, because π^* preserves \mathbb{W} -locally constant presheaves. So the composite is also left Quillen. \square

10.2. Left localisable substitutes. Let (P, A) be a $\mathbb{S}et$ -substitute. Let \mathbb{W} be a proper fundamental localiser and let \mathbb{V} be a symmetric monoidal combinatorial model category. The projective semimodel structure on $\mathbb{A}lg_P(\mathbb{V})$ is, by definition, the semimodel structure transferred along $U_P : \mathbb{A}lg_P(\mathbb{V}) \rightarrow [A, \mathbb{V}]_{proj}$ or, equivalently, along the composite

$$\mathbb{A}lg_P(\mathbb{V}) \xrightarrow{\eta^*} [A, \mathbb{V}] \xrightarrow{i^*} [A_0, \mathbb{V}].$$

Assuming the existence of such a transfer we can try to lift the localisation $[A, \mathbb{V}]_{proj} \rightarrow [A, \mathbb{V}]_{proj}^{\mathbb{W}}$ to the category of P -algebras to obtain the localisation $\mathbb{A}lg_P^{\mathbb{W}}(\mathbb{V})$.

Definition 10.2.1. A P -algebra X is called \mathbb{W} -locally constant if its underlying presheaf $\eta^*(X) : A \rightarrow \mathbb{V}$ is a \mathbb{W} -locally constant presheaf.

Theorem 10.2.2. *If \mathbb{V} is a symmetric monoidal combinatorial model category and (P, A) is a Σ -free $\mathbb{S}et$ -substitute then*

- (1) *The projective semimodel structure on $\mathbb{A}lg_P(\mathbb{V})$ exists;*
- (2) *For any proper fundamental localiser the local semimodel model structure $\mathbb{A}lg_P^{\mathbb{W}}(\mathbb{V})$ exists and its fibrant objects are exactly \mathbb{W} -locally constant P -algebras;*
- (3) *The local model structure $\mathbb{A}lg_P^{\mathbb{W}}(\mathbb{V})$ coincides with the transferred semimodel structure along the forgetful functor $U : \mathbb{A}lg_P(\mathbb{V}) \rightarrow [A, \mathbb{V}]_{proj}^{\mathbb{W}}$ provided this transferred semimodel structure exists.*

Proof. The existence of the projective structure on $\mathbb{A}lg_P(\mathbb{V})$ is proved in [WY16].

The existence of the local semimodel structure $\mathbb{A}lg_P^{\mathbb{W}}(\mathbb{V})$ follows from Theorem 3.0.4. Point (3) of the theorem follows from Theorem 5.6 of [BW16]. \square

By default we assume that $\mathbb{A}lg_P(\mathbb{V})$ is equipped with the projective semimodel structure.

Definition 10.2.3. We will say that a Σ -free substitute (P, A) is left localisable if for any symmetric monoidal combinatorial model category \mathbb{V} with cofibrant unit I and a proper fundamental localiser \mathbb{W} the local semimodel structure $\text{Alg}_P^{\mathbb{W}}(\mathbb{V})$ is transferred from $[A, \mathbb{V}]_{proj}^{\mathbb{W}}$ and the forgetful functor $U_P : \text{Alg}_P(\mathbb{V}) \rightarrow [A, \mathbb{V}]_{proj}$ preserves cofibrant objects.

Since cofibrant objects in $[A, \mathbb{V}]_{proj}$ and $[A, \mathbb{V}]_{proj}^{\mathbb{W}}$ coincide we have for a left localisable substitute that $U_P : \text{Alg}_P(\mathbb{V}) \rightarrow [A, \mathbb{V}]_{proj}^{\mathbb{W}}$ also preserves cofibrant objects. Immediately from Theorem 8.5.5 we have

Corollary 10.2.4. *Let \mathbb{V} be symmetric monoidal combinatorial model category with cofibrant unit and let \mathbb{W} be a proper fundamental localiser. If $(f, g) : (P, A) \rightarrow (Q, B)$ is a Beck-Chevalley morphism between left localisable substitutes then:*

- (1) *The morphism $(f, g) : (P, A) \rightarrow (Q, B)$ is also homotopically Beck-Chevalley with respect to local model structures $[A, \mathbb{V}]_{proj}^{\mathbb{W}}$ and $[B, \mathbb{V}]_{proj}^{\mathbb{W}}$;*
- (2) *If g is a \mathbb{W} -equivalence then the adjoint pair $f_! \dashv f^*$ is a Quillen equivalence between $\text{Alg}_P^{\mathbb{W}}(\mathbb{V})$ and $\text{Alg}_Q^{\mathbb{W}}(\mathbb{V})$.*

We need a criteria for recognition of left localisable substitutes. We first establish a sufficient combinatorial condition for a substitute to be left Quillen:

Proposition 10.2.5. *Let \mathbb{V} be symmetric monoidal combinatorial model category with cofibrant unit and let (P, A) be a Σ -free substitute. Then:*

- (1) *(P, A) is left Quillen with respect to $[A, \mathbb{V}]_{proj}$ if the bimodule $d(P)$ is disconnected (cf. (5.2.9)).*
- (2) *(P, A) is left Quillen with respect to $[A, \mathbb{V}]_{proj}^{\mathbb{W}}$ for any proper fundamental localiser \mathbb{W} if $d(P)$ is constantly disconnected.*

Proof. We can use the formula (5.2.11) for convolution. Disconnectedness of $d(P)$ implies that $\pi_1'(p')^*$ is a left Quillen functor with respect to the projective model structure and is left Quillen with respect to local model structure if $d(P)$ is constantly disconnected by Proposition 10.1.5. Thus to finish the proof of the first point of the proposition, it is enough to show that $\tilde{\otimes}^k$ is left Quillen. It follows from Barwick's results [Bar10, Propositions 3.43 and 4.50] that the functor

$$\tilde{\otimes}^2 : [A, \mathbb{V}]_{proj} \times [A, \mathbb{V}]_{proj} \rightarrow [A \times A, \mathbb{V}]_{proj}$$

is a left Quillen functor of two variables. Applying this result and an obvious induction to our case, we complete the proof.

To prove that (P, A) is left Quillen with respect to $[A, \mathbb{V}]_{proj}^{\mathbb{W}}$ (using formula (5.2.11) again) we see that it is enough to prove that the functor $\tilde{\otimes}^2$ is a left Quillen functor for the local model structure as well. By the usual adjunction argument this comes down to the following statement of preservation of local objects:

Let $Z : A \times A \rightarrow \mathbb{V}$ be a \mathbb{W} -locally constant fibrant presheaf. Then for a cofibrant $Y : A \rightarrow \mathbb{V}$ the presheaf $[A, \mathbb{V}](Y, Z(s, -))$, $s \mapsto \int_t \underline{\mathbb{V}}(Y(t), Z(s, t))$ is a \mathbb{W} -locally constant presheaf. Here $\underline{\mathbb{V}}$ and $\underline{[A, \mathbb{V}]}$ are internal hom-functors in \mathbb{V} and $[A, \mathbb{V}]$ correspondingly.

We know that Z is equivalent to a constant presheaf after restriction to any \mathbb{W} -aspherical category $B' \rightarrow A \times A$. So, for an arbitrary \mathbb{W} -aspherical A' and a functor $u : A' \rightarrow A$ there is a levelwise weak equivalence $(1_s \times u)^*(Z) \rightarrow C_s$ to a constant presheaf C_s , where $1_s : 1 \rightarrow A$ is the functor that picks $s \in A$. We can obviously

assume that C_s is fibrant. Since Y is cofibrant and Z is fibrant we have a levelwise weak equivalence

$$\int_t \underline{\mathbb{V}}(Y(t), Z(s, t)) \rightarrow \int_t \underline{\mathbb{V}}(Y(t), C_s(t)).$$

The last functor is obviously constant. □

Finally, applying Theorem 8.1.7 we get the following combinatorial criteria for localisability

Theorem 10.2.6. *Let (P, A) be a unary tame substitute for which $d(P)$ is constantly disconnected. Then (P, A) is left localisable.*

10.3. First examples and applications.

Example 10.3.1. The classical theory of localisation in a category begins from a class of morphisms A in a category C which we want to invert. The class A generates a subcategory A in C and we can assume that $A \mapsto C$ is the identity on objects. The localisation $C \rightarrow C[A^{-1}]$ is characterised by the universal property that $[C[A^{-1}], \mathbb{V}]$ is exactly the subcategory of presheaves $[C, \mathbb{V}]$ whose restriction on any morphism from A is an isomorphism. Here \mathbb{V} is any category. If $A = C$ we get $C[C^{-1}] \cong \Pi_1(C)$ the fundamental groupoid of C and the ‘equation’:

$$[C[C^{-1}], \mathbb{V}] \cong [\Pi_1(C), \mathbb{V}].$$

Cisinski’s localisation $[C, \mathbb{V}]_{proj}^{W_\infty}$ does exactly the same for the ‘inversion’ of morphisms up to all higher homotopies. More precisely, there is an ∞ -equivalence of $(\infty, 1)$ -categories:

$$[C, \mathbb{V}]_{proj}^{W_\infty} \rightarrow [\Pi_\infty(C), \mathbb{V}]$$

where Π_∞ is the ∞ -fundamental groupoid of C (cf. discussion in Section 1.2 [Cis09])

It is natural to ask if we can get a version of Cisinski’s localisation when we are interested in the weak ‘inversion’ of morphisms from a subcategory A , and, more generally, with respect to a proper fundamental localiser W . One way to achieve this is to repeat the proof of Theorem 9.3.4 by considering functors from W -aspherical categories A' to C which are factorisable through A .

A quicker way is to consider the pair (C, A) as a substitute and apply Theorem 10.2.6 to this substitute. It is trivial to check that all the conditions of this theorem are satisfied in this case.

Example 10.3.2. In this example we consider a monoidal version of Cisinski localisation. More precisely, let (C, \otimes, e) be a (strict) monoidal small category and $\alpha : A \subset C$ be an identity-on-objects monoidal inclusion. We can construct a non-symmetric substitute (P_C, A) out of this pair in a standard way. Namely,

$$P_C(a_1, \dots, a_n; a) = C(a_1 \otimes \dots \otimes a_n, a),$$

$$\alpha : A(a_1, a_2) \rightarrow C(a_1, a_2).$$

The category of algebras of this substitute is the category $\text{Mon}[C, \mathbb{V}]$ of lax-monoidal functors $F : C \rightarrow \mathbb{V}$ and their monoidal transformations. It is well-known that this is also equivalent to the category of monoids in $[C, \mathbb{V}]$ with respect to Day’s convolution, hence the notation.

Proposition 10.3.3. *The substitute (P_C, A) is left localisable.*

Proof. We have to check that (P_C, A) is unary tame and $d(P_C)$ is constantly disconnected. In fact, (P_C, A) is even a tame substitute. The classifier $\mathcal{P}_C^{\mathcal{P}_C + A}$ can be easily described. Its objects are morphisms in C of the form:

$$f : \sigma(X_1 \otimes X_2 \otimes \cdots \otimes X_p \otimes K_1 \dots \otimes K_q) \rightarrow X$$

where σ is a (p, q) -shuffle, plus one more object $\emptyset \rightarrow e$. A morphism $\phi : h \rightarrow f$ in this classifier is given by a sequence of objects $f_i : X_1^i \otimes \dots \otimes X_{n_i}^i \rightarrow X_i$, $1 \leq i \leq p$ in $\mathcal{P}_C^{\mathcal{P}_C + A_0}$ and a sequence of morphisms in A $g_j : K_j \rightarrow K_j$, $1 \leq j \leq q$ such that h is equal to the composite

$$f(\sigma(f_1 \otimes \dots \otimes f_p \otimes g_1 \otimes \dots \otimes g_q)).$$

In this description we also assume that one of the objects X_i in the domain of f can be equal to the tensor unit of C and in this case f_i has an empty string as its domain.

We now show that the subcategory τ in the connected components of \mathcal{P}_C^{A+A} which consists of the morphisms of C whose domain are alternating strings:

$$X_1 \otimes K_1 \otimes X_2 \otimes \dots \otimes K_n \otimes X_{n+1} \rightarrow X$$

is final in $\mathcal{P}_C^{\mathcal{P}_C + A}$. Indeed, an arbitrary morphism h can be factored through a morphism of this type. For this we consider a canonical bracketing of the domain of h where we put brackets on the maximal substrings of objects of X -type (including empty strings if necessary). We then take as f_i on the i -th substring the identity morphism or the special morphism $\emptyset \rightarrow e$. For example, if h is

$$X_1 \otimes X_2 \otimes K_1 \otimes K_2 \rightarrow X$$

we factor it as

$$X_1 \otimes X_2 \otimes K_1 \otimes K_2 \rightarrow (X_1 \otimes X_2) \otimes K_1 \otimes e \otimes K_2 \otimes e \rightarrow X,$$

where $f_1 = id : X_1 \otimes X_2 \rightarrow X_1 \otimes X_2$, $f_2 : \emptyset \rightarrow e$, and $f_3 : \emptyset \rightarrow e$. Hence, the category f/τ is nonempty for all f . It is not hard to see that, in fact, the object of τ constructed above is the terminal object in f/τ , hence, τ is a final subcategory.

The bimodule $d(P_C)$ is equal to P_C in this case since we work with a nonsymmetric substitute. The category $\int P_C$ has objects the morphisms $f : a_1 \otimes \dots \otimes a_n \rightarrow a$ in C . A morphism from $a_1 \otimes \dots \otimes a_n \xrightarrow{f} a$ to $b_1 \otimes \dots \otimes b_n \xrightarrow{h} b$ is given by an n -tuple of morphisms in A , $f_i : a_i \rightarrow b_i$, and $g : a \rightarrow b$ such that the following square commutes:

$$(10.3.1) \quad \begin{array}{ccc} a_1 \otimes \dots \otimes a_n & \xrightarrow{f} & a \\ f_1 \otimes \dots \otimes f_n \downarrow & & \downarrow g \\ b_1 \otimes \dots \otimes b_n & \xrightarrow{h} & b. \end{array}$$

The functor $p : \int P_C \rightarrow \mathbf{MA}$ (Section 5.2) sends an object $f : a_1 \otimes \dots \otimes a_n \rightarrow a$ to the string (a_1, \dots, a_n) . Now the comma-category of p under $X = (a_1, \dots, a_n)$ has an initial object given by $u : X \rightarrow p(Y)$, where Y is the object in $\int P_C$ given by $id : a_1 \otimes \dots \otimes a_n \rightarrow a_1 \otimes \dots \otimes a_n$ and components of u are also the identities $id : a_1 \rightarrow a_1, \dots, id : a_n \rightarrow a_n$. Notice that the requirement that A is closed under tensor product operation is used exactly here. This completes the proof. \square

We thus have

Proposition 10.3.4. *Let \mathbb{V} be a combinatorial symmetric monoidal model category with cofibrant unit and let \mathbb{W} be a proper fundamental localiser. Let C be a small monoidal category and $A \subset C$ be its monoidal subcategory with the same objects. Then there exists a local semimodel category $\text{Mon}[C, \mathbb{V}]_{\text{proj}}^{\mathbb{W}}[A^{-1}]$ whose fibrant objects are lax monoidal functors with fibrant values whose restriction on A are \mathbb{W} -locally constant.*

We can say more in the case $A = C$. We denote the corresponding localised model category simply $\text{Mon}[C, \mathbb{V}]_{\text{proj}}^{\mathbb{W}}$.

Proposition 10.3.5. *For any strict monoidal functor $F : C \rightarrow D$ between small monoidal categories, the induced morphism of substitutes $(f, F) : (P_C, C) \rightarrow (P_D, D)$ is Beck-Chevalley.*

Proof. We apply Theorem 6.3.4. We need to show that the morphism of classifiers

$$\mathcal{D}^C \rightarrow \alpha^* \mathcal{P}_D^{P_C}$$

is a final functor. Recall that $\alpha : \mathcal{D} \rightarrow \mathcal{P}_D$ is the morphism between polynomial monads generated by unit of the substitute (P_D, D) .

The finality of this functor is equivalent to the statement that, for any fixed morphism $\phi : F(c_1 \otimes \dots \otimes c_n) \rightarrow d$, the following category of factorisations of ϕ is nonempty and connected. Objects of this category are pairs of morphisms $h : c_1 \otimes \dots \otimes c_n \rightarrow b$, $g : F(b) \rightarrow d$ such that ϕ is factorised as $F(h)$ followed by g . A morphism from such a pair to a pair $h' : c_1 \otimes \dots \otimes c_n \rightarrow b'$, $g' : F(b') \rightarrow d$ is given by a morphism $t : b \rightarrow b'$ making the following diagram commute:

$$\begin{array}{ccc} F(c_1 \otimes \dots \otimes c_n) & \xrightarrow{F(h')} & F(b') \\ F(h) \downarrow & \nearrow F(t) & \downarrow g' \\ F(b) & \xrightarrow{g} & d. \end{array}$$

It is obvious that the category of factorisations has an initial object given by the pair $id : c_1 \otimes \dots \otimes c_n \rightarrow c_1 \otimes \dots \otimes c_n$, $\phi : F(c_1 \otimes \dots \otimes c_n) \rightarrow d$. Hence, it is nonempty and connected, as required. \square

Corollary 10.3.6. *Let \mathbb{W} be a proper fundamental localiser, let C and D be small monoidal categories, and let \mathbb{V} be a combinatorial symmetric monoidal model category with cofibrant unit. Any monoidal \mathbb{W} -equivalence $C \rightarrow D$ induces a Quillen equivalence between $\text{Mon}[C, \mathbb{V}]_{\text{proj}}^{\mathbb{W}}$ and $\text{Mon}[D, \mathbb{V}]_{\text{proj}}^{\mathbb{W}}$.*

If (C, \otimes, e) is a \mathbb{W} -aspherical monoidal category then there exists a Quillen equivalence between $\text{Mon}[C, \mathbb{V}]_{\text{proj}}^{\mathbb{W}}$ and the category $\text{Mon}(\mathbb{V})$ of monoids in \mathbb{V} .

Proof. The unique functor $C \rightarrow 1$ is the monoidal \mathbb{W} -equivalence. The category $\text{Mon}[1, \mathbb{V}]_{\text{proj}}^{\mathbb{W}}$ is obviously just $\text{Mon}(\mathbb{V})$ with the projective model structure. \square

Remark 10.3.7. It is tempting to try to develop a theory of monoidal localisation for braided monoidal and symmetric monoidal functors. Unfortunately, our present technique is not enough for this purpose, since the corresponding substitute P_C is not Σ -free for a braided monoidal C . Conditions under which algebras still have

a transferred (semi)model structure, even without Σ -freeness, may be found in [WY18].

Part 4. Higher braided operads

In this part, we provide our main applications of the theorems above.

11. n -OPERADS

In this section, we review the basics of n -operads, previously studied by the first author in [Bat07, Bat08, Bat10, Bat17]. Algebras over n -operads have the requisite structure to model n -tuply monoidal $(n+k)$ -categories, as required for the Baez-Dolan Stabilisation Hypothesis [BD95]. We begin with the structure that underlies an n -operad.

11.1. n -ordinals and quasibijections.

Definition 11.1.1. Let T be a finite set equipped with n binary relations

$$\langle_0, \dots, \langle_{n-1}.$$

T is called an n -ordinal if these relations satisfy the following properties

- (1) \langle_p is nonreflexive;
- (2) for every pair $a, b \in T$, there exists exactly one p such that

$$a \langle_p b \text{ or } b \langle_p a;$$

- (3) if $a \langle_p b$ and $b \langle_q c$ then $a \langle_{\min(p,q)} c$.

Every n -ordinal can be represented as a pruned planar tree with n levels (pruned n -tree) or as an n -dimensional globular graph (see [Bat07] for a discussion). The empty n -ordinal is represented by the only degenerate pruned n -tree $z^n U_0$ which consists of only a root on the level 0. The terminal n -ordinal is represented by a linear tree U_n (or just an n -globe in globular notation).

Definition 11.1.2. A map of n -ordinals

$$\sigma : T \rightarrow S$$

is a map $\sigma : T \rightarrow S$ of underlying sets such that

$$i \langle_p j \text{ in } T$$

implies that

- (1) $\sigma(i) \langle_r \sigma(j)$ for some $r \geq p$ or
- (2) $\sigma(i) = \sigma(j)$ or
- (3) $\sigma(j) \langle_r \sigma(i)$ for $r > p$.

For every $i \in S$ the preimage $\sigma^{-1}(i)$ (*the fiber of σ over i*) has a natural structure of an n -ordinal.

A *total order* on an n -ordinal T is a linear order $<$ on the underlying set of T defined as follows:

$$a < b \text{ iff } a \langle_r b \text{ for some } 0 \leq r \leq n-1.$$

We will denote by $[T]$ the set T with its total linear order. In this way we have a monoidal functor

$$[-] : \text{Ord}(n) \rightarrow \text{FinSet},$$

where FinSet is a skeletal version of the category of finite sets whose objects are finite ordinals $1 < \dots < n$.

We also introduce the category of ∞ -ordinals $\text{Ord}(\infty)$.

Definition 11.1.3. Let T be a finite set equipped with a sequence of binary relations $<_0, <_{-1} \dots, <_p, <_{p-1} \dots$ for all integers $p \leq 0$. The set T is called an ∞ -ordinal if these relations satisfy the following properties:

- (1) $<_p$ is nonreflexive;
- (2) for every pair $a, b \in T$, there exists exactly one p such that

$$a <_p b \text{ or } b <_p a;$$

- (3) if $a <_p b$ and $b <_q c$ then $a <_{\min(p,q)} c$.

The definition of morphisms between ∞ ordinals coincides with the Definition 11.1.2. The category $\text{Ord}(\infty)$ is *the skeletal category of ∞ -ordinals*. As for $\text{Ord}(n)$ we have a functor of total order

$$[-] : \text{Ord}(\infty) \rightarrow \text{FinSet}.$$

Definition 11.1.4. A map of n -ordinals is called a quasibijection if it is a bijection of the underlying sets.

Let \mathbb{Q}_n (for $1 \leq n \leq \infty$) be *the subcategory of quasibijections of $\text{Ord}(n)$* and let \mathbb{S} be the groupoid of invertible morphisms in FinSet which is isomorphic to the groupoid of symmetric groups. The total order functor induces a functor which we will denote by the same symbol:

$$[-] : \mathbb{Q}_n \rightarrow \mathbb{S}.$$

For $n = 2$ it was shown in [Bat10] that $[-]$ is factorised through the groupoid of braid groups Br .

It is clear that the category \mathbb{Q}_n is the union of connected components $\mathbb{Q}_n(k)$ where k is the cardinality of the n -ordinals.

Theorem 11.1.5. (1) *For a finite n , the nerve $N(\mathbb{Q}_n(k))$ has the homotopy type of unordered configuration spaces of k -points in \mathbb{R}^n ;*

- (2) *The functor*

$$[-] : \mathbb{Q}_\infty \rightarrow \mathbb{S},$$

induces a weak equivalence of nerves;

- (3) *The fiber of the functor $[-] : \mathbb{Q}_n \rightarrow \mathbb{S}$ over an object $\bar{k} \in \mathbb{S}$ is isomorphic to the Milgram poset $J_n(k)$.*

- (4) *For $n \geq 3$ the functor $[-] : \mathbb{Q}_n \rightarrow \mathbb{S}$ is \mathbb{W}_k -aspherical for $0 \leq k \leq n - 1$.*

- (5) *For $n = 2$ the functor $[-]_2 : \mathbb{Q}_2 \rightarrow \text{Br}$ is a k -equivalence for $1 \leq k \leq \infty$.*

Proof. Most of the statements of this theorem are just reformulations of statements of Theorem 5.1 and Lemma 5.1 from [Bat10]. We add the proof of the point (2). Asphericity of $[-]$ follows immediately.

Recall that $J_n(k)$ is the Milgram poset of all possible n -ordinal structures on the set $\{1, \dots, k\}$ ([Bat07, Remark 2.2] and Section 13.1 for a detailed definition). The group \mathbb{S}_k acts on $J_n(k)$ and the quotient $J_n(k)/\mathbb{S}_k$ is isomorphic to $\mathbb{Q}_n(k)$. The homotopy type of $N(J_n(k))$ coincides with the homotopy type of the ordered configuration space of k points in \mathbb{R}^n (see the end of the proof of [Bat10, Theorem 5.1]).

One can think of an element from $J_n(k)$ as a pair (T, π) where T is an n -ordinal and π is a permutation from S_k and $(T, \pi) > (S, \xi)$ in $J_n(k)$ when there exists a quasibijection $\sigma : T \rightarrow S$ and $\xi \cdot \pi = \sigma$.

One can identify then the category $J_n(k)$ with the comma-category $[-] : Q_n(k) \rightarrow S(k)$. An object of the comma-category $|-|/k$ is exactly $T \in Q_n(k)$ equipped with a permutation $\pi : |T| \rightarrow \star$ that is an object of $J_n(k)$. Morphisms also coincide with the description above. \square

11.2. n -operads. We now recall the definition of pruned $(n-1)$ -terminal n -operad [Bat07]. Since we do not need other types of n -operads in this paper we will call them simply n -operads. The notation U_n means the terminal n -ordinal.

Let \mathbb{V} be a symmetric monoidal category. For a morphism of n -ordinals $\sigma : T \rightarrow S$ the n -ordinal T_i is the fiber $\sigma^{-1}(i)$.

Definition 11.2.1. An n -operad in \mathbb{V} is a collection A_T , $T \in Ord(n)$ of objects of \mathbb{V} equipped with the following structure :

- a morphism $e : I \rightarrow A_{U_n}$ (the unit);
- for every morphism $\sigma : T \rightarrow S$ in $Ord(n)$, a morphism

$$m_\sigma : A_S \otimes A_{T_0} \otimes \dots \otimes A_{T_k} \rightarrow A_T \quad (\text{the multiplication}).$$

They must satisfy the following identities:

- for any composite

$$T \xrightarrow{\sigma} S \xrightarrow{\omega} R,$$

the associativity diagram

$$\begin{array}{ccc}
 A_R \otimes A_{S_\bullet} \otimes A_{T_0^\bullet} \otimes \dots \otimes A_{T_i^\bullet} \otimes \dots \otimes A_{T_k^\bullet} & \simeq & A_R \otimes A_{S_0} \otimes A_{T_1^\bullet} \otimes \dots \otimes A_{S_i} \otimes A_{T_i^\bullet} \otimes \dots \otimes A_{S_k} \otimes A_{T_k^\bullet} \\
 \downarrow & & \downarrow \\
 A_S \otimes A_{T_1^\bullet} \otimes \dots \otimes A_{T_i^\bullet} \otimes \dots \otimes A_{T_k^\bullet} & & A_R \otimes A_{T_\bullet} \\
 \searrow & & \swarrow \\
 & A_T &
 \end{array}$$

commutes, where

$$A_{S_\bullet} = A_{S_0} \otimes \dots \otimes A_{S_k},$$

$$A_{T_i^\bullet} = A_{T_i^0} \otimes \dots \otimes A_{T_i^{m_i}}$$

and

$$A_{T_\bullet} = A_{T_0} \otimes \dots \otimes A_{T_k};$$

- for an identity $\sigma = id : T \rightarrow T$ the diagram

$$\begin{array}{ccc}
 A_T \otimes A_{U_n} \otimes \dots \otimes A_{U_n} & \longleftarrow & A_T \otimes I \otimes \dots \otimes I \\
 \downarrow & \swarrow id & \\
 A_T & &
 \end{array}$$

commutes;

- for the unique morphism $T \rightarrow U_n$ the diagram

$$\begin{array}{ccc}
 A_{U_n} \otimes A_T & \longleftarrow & I \otimes A_T \\
 \downarrow & \swarrow \text{id} & \\
 A_T & &
 \end{array}$$

commutes.

n -operads form a category which we will denote $O_n(\mathbb{V})$.

A *constant free n -operad* is defined in a way similar to an n -operad but we do not include the object $A_{z^n U_0}$ in the definition. We also require the maps of n -ordinals used in this definition to be surjections. Analogously we define a *constant free symmetric operad* as a classical symmetric operad without a 0-term. The category of constant free n -operads is denoted $CFO_n(\mathbb{V})$.

Finally, a constant free n -operad (constant free symmetric operad) is called *normal* if $A_{U_n} = I$ (resp. $A_1 = I$) is the tensor unit of the category \mathbb{V} . The subcategory of normal n -operads is denoted by $NO_n(\mathbb{V})$.

To shorten our exposition we accept the following agreement.

Agreement 11.2.2. Any n -operads or symmetric operads we will use may have three types: general, constant free or normal. We assume throughout the text that the type of operads is fixed and we will use the notations $Op_n(\mathbb{V})$ ($SO(\mathbb{V}), BO(\mathbb{V})$) for the category of n -operads (symmetric operads and braided operads correspondingly) of this fixed type unless we specifically indicate what type of operads we have in mind.

11.3. Symmetrization of n -operads. Let $\sigma : T \rightarrow S$ be a quasibijection and A be an n -operad. Since a fiber of σ is the terminal n -ordinal U_n , the multiplication

$$\mu_\sigma : A_S \otimes (A_{U_n} \otimes \dots \otimes A_{U_n}) \longrightarrow A_T$$

in composition with the morphism

$$A_S \rightarrow A_S \otimes (I \otimes \dots \otimes I) \rightarrow A_S \otimes (A_{U_n} \otimes \dots \otimes A_{U_n})$$

induces a morphism

$$A(\sigma) : A_S \rightarrow A_T.$$

It is not hard to see that in this way A becomes a functor on Q_n^{op} . So we have a forgetful functor from the category of n -operads $Op_n(\mathbb{V})$ to the category $[Q_n^{op}, \mathbb{V}]$.

The desymmetrisation functor des_n from symmetric operads to n -operads, for finite n , was defined in [Bat08] using pullback along the functor $[-] : Ord(n) \rightarrow \text{FinSet}$. It was shown that this functor has a left adjoint which we call symmetrisation and denote sym_n .

Since n -operads are algebras of a Σ -free coloured operad [BB17] whose underlying category is the opposite to the category of quasibijections, one considers a Σ -free substitute $(O^{(n)}, Q_n^{op})$ whose algebras in \mathbb{V} are n -operads of a given type (see Appendix 13). We also consider a Σ -free symmetric substitute (SO, S^{op}) whose algebras are symmetric operads (we again use Agreement 11.2.2 about different types of operads). Similarly we get a substitute (BO, Br^{op}) for braided operads and braided collections.

Remark 11.3.1. To construct the substitute (BO, Br^{op}) we need to use *vines* in \mathbb{R}^3 [Lav97] instead of planar trees but otherwise the construction is similar to (SO, S^{op}) .

The adjoint pair of symmetrisation and desymmetrisation is then induced by a substitute map:

$$(\tau, [-]^{op}) : (O^{(n)}, Q_n^{op}) \rightarrow (SO, S^{op}).$$

The first component τ sends a tree decorated by n -ordinals to its underlying tree. The desymmetrisation and symmetrisation functors are τ^* and $\tau_!$ correspondingly [Bat17]. To shorten the notation we will denote the functor $[-]^{op}$ by $[-]$. Since S is a groupoid, this should not lead to any confusion.

The adjunction between braided and symmetric operads admits a similar treatment. Namely, the canonical map π from braid groups to symmetric groups can be extended to a map of substitutes:

$$(\theta, \pi^{op}) : (BO, \text{Br}^{op}) \rightarrow (SO, S^{op}).$$

and $(\tau, [-]^{op}) : (O^{(2)}, Q_2^{op}) \rightarrow (SO, S^{op})$ is factorised as

$$(O^{(2)}, Q_2^{op}) \xrightarrow{(\kappa, [-]_2^{op})} (BO, \text{Br}^{op}) \xrightarrow{(\theta, \pi^{op})} (SO, S^{op}).$$

Proposition 11.3.2. *The morphisms of substitutes $(\tau, [-]^{op})$, $(\kappa, [-]_2^{op})$ and (θ, π^{op}) are Beck-Chevalley morphisms.*

Proof. We have to prove that the following commutative square of adjunctions is Beck-Chevalley.

$$(11.3.1) \quad \begin{array}{ccc} Op_n(\mathbb{V}) & \xrightleftharpoons[\perp]{sym_n} & SO(\mathbb{V}) \\ \uparrow F_n \downarrow U_n & & \uparrow F \downarrow U \\ [Q_n^{op}, \mathbb{V}] & \xrightleftharpoons[\perp]{[-]!} & [S^{op}, \mathbb{V}] \\ & & \downarrow [-]^* \end{array}$$

According to Theorem 6.3.4 we need to establish that the commutative square of polynomial monads

$$(11.3.2) \quad \begin{array}{ccc} \mathcal{O}_n & \xrightarrow{\tau} & \mathcal{SO} \\ \uparrow \beta & & \uparrow \alpha \\ Q_n^{op} & \xrightarrow{[-]^{op}} & S^{op} \end{array}$$

is exact. That is that the induced morphism of classifiers

$$(11.3.3) \quad S^{op} Q_n^{op} \rightarrow \alpha^*(\mathcal{SO}^{\mathcal{O}_n})$$

is a final functor.

The classifier $\mathcal{SO}^{\mathcal{O}_n}$ has been described in [Bat07]. The classifier $S^{op} Q_n^{op}$ is isomorphic to $J_n^{op} = \coprod_k (J_n)_k^{op}$ as was shown in the proof of Theorem 11.1.5. The finality of the inclusion $J_n^{op} \subset \mathcal{SO}^{\mathcal{O}_n}$ is the content of Lemma 4.3 from [Bat07].

For the morphism (θ, π^{op}) it is enough to observe that both $\pi_!$ and $\theta_!$ on underlying collections are given by quotient with respect to the action of pure braid groups.

Finally, the morphism $(\kappa, [-]_2^{op})$ is Beck-Chevalley by Proposition 8.5.4.

□

12. LOCALLY CONSTANT n -OPERADS

In this section we assume that \mathbb{W} is a proper fundamental localiser and \mathbb{V} is a combinatorial monoidal model category with the cofibrant tensor unit.

12.1. Locally constant n -operads, recollection.

Definition 12.1.1. A \mathbb{W} -locally constant n -operad in \mathbb{V} is an n -operad A in \mathbb{V} such that its underlying Q_n^{op} -presheaf is \mathbb{W} -locally constant.

When $\mathbb{W} = \mathbb{W}_\infty$ this definition coincides with the definition of locally constant n -operad from [Bat10].

A morphism of n -operads is a weak equivalence if it is a termwise weak equivalence of the collections. The homotopy category of operads is the category of operads localised with respect to the class of weak equivalences. Let $LCO_n^{\mathbb{W}}(\mathbb{V})$ be the full subcategory of the homotopy category of $O_n(\mathbb{V})$ of \mathbb{W} -locally constant n -operads. For $\mathbb{W} = \mathbb{W}_\infty$ we will refer to the category $LCO_n^{\mathbb{W}_\infty}(\mathbb{V})$ as the homotopy category of locally constant operads to maintain the terminology of [Bat10].

For $n = 1$ the category $LCO_1^{\mathbb{W}_\infty}(\mathbb{V})$ is isomorphic to the homotopy category of nonsymmetric operads, and the (derived) symmetrisation functor is given by multiplication on symmetric groups. The following theorem combines Theorem 7.1 and 7.2 of [Bat10].

Theorem 12.1.2 ([Bat10]). (1) *The homotopy category of locally constant 2-operads and the homotopy category of braided operads are equivalent.*
 (2) *The homotopy category of locally constant ∞ -operads, the homotopy category of quasisymmetric ∞ -operads, and the homotopy category of symmetric operads are equivalent.*

12.2. Model theoretical refinement. The purpose of this section is to lift Theorem 12.1.2 to the model categorical level.

To further simplify notations we write $[Q_n^{op}, \mathbb{V}]$ for the model category $[Q_n^{op}, \mathbb{V}]_{proj}$. We use the notation $Op_n^{\mathbb{W}}(\mathbb{V}) = \text{Alg}_{O(n)}^{\mathbb{W}}(\mathbb{V})$ for the category of n -operads equipped with the local semimodel structure provided by p.2 of Theorem 10.2.2 (that is lifted from $[Q_n^{op}, \mathbb{V}]^{\mathbb{W}}$). The fibrant objects in $Op_n^{\mathbb{W}}(\mathbb{V})$ are termwise fibrant \mathbb{W} -locally constant n -operads.

We use a similar construction for symmetric operads. We define the \mathbb{W} -local semimodel category of symmetric operads $SO^{\mathbb{W}}(\mathbb{V})$ (braided operads $BO^{\mathbb{W}}(\mathbb{V})$) as a lifting along the forgetful functor $U : SO(\mathbb{V}) \rightarrow [S^{op}, \mathbb{V}]$ ($BO(\mathbb{V}) \rightarrow [Br^{op}, \mathbb{V}]$) of the localisation $[S^{op}, \mathbb{V}] \rightarrow [S^{op}, \mathbb{V}]^{\mathbb{W}}$ ($[Br^{op}, \mathbb{V}] \rightarrow [Br^{op}, \mathbb{V}]^{\mathbb{W}}$).

We then have:

Proposition 12.2.1. *Let \mathbb{V} be symmetric monoidal combinatorial model category with cofibrant tensor unit. Then:*

- (1) *The homotopy category $Ho(Op_n^{\mathbb{W}}(\mathbb{V}))$ is equivalent to the homotopy category of \mathbb{W} -locally constant n -operads $LCOp_n^{\mathbb{W}}(\mathbb{V})$. In particular, the category $Ho(Op_n^{\mathbb{W}_\infty}(\mathbb{V}))$ is equivalent to the category of locally constant n -operads.*
- (2) *The homotopy category $Ho(SO^{\mathbb{W}}(\mathbb{V}))$ ($Ho(BO^{\mathbb{W}}(\mathbb{V}))$) is equivalent to the homotopy category of the category of symmetric (braided) operads whose underlying symmetric (braided) collection is fibrant and \mathbb{W} -locally constant.*
- (3) *For $k \geq 1$ the categories $SO^{\mathbb{W}_k}(\mathbb{V})$ and $[S^{op}, \mathbb{V}]^{\mathbb{W}_k}$ ($BO^{\mathbb{W}_k}(\mathbb{V})$ and $[Br^{op}, \mathbb{V}]^{\mathbb{W}_k}$) are isomorphic to $SO(\mathbb{V})$ and $[S^{op}, \mathbb{V}]$ ($BO(\mathbb{V})$ and $[Br^{op}, \mathbb{V}]$) correspondingly as (semi)model categories.*

- (4) *The category $\text{Ho}(SO(\mathbb{V})^{\mathbb{W}_0})$ ($\text{Ho}(BO(\mathbb{V})^{\mathbb{W}_0})$) is equivalent to the homotopy category of operads whose underlying symmetric (braided) collection has a homotopically trivial action of symmetric (braid) groups (meaning that such a collection is equivalent to a constant collection).*

Proof. We only need to prove the statements (3) and (4). Since S^{op} is a groupoid, then any functor on it is \mathbb{W}_∞ -locally constant. The statement then amounts to the following general fact. Let G be a groupoid. Then any functor $G \rightarrow \mathbb{V}$ is \mathbb{W}_k -locally constant for any $k \geq 1$. Indeed, let A' be a \mathbb{W}_k -aspherical category and $u : A' \rightarrow G$ be a functor. Then u can be factorised through the fundamental groupoid of A' :

$$A' \rightarrow \Pi_1(A') \rightarrow G$$

and, since A' has trivial π_0 and π_1 , the fundamental groupoid $\Pi_1(A')$ is trivial as well. So, $u^*(F)$ is equivalent to a constant functor.

For the third statement observe that S_n is a connected groupoid for all $n \geq 0$. Therefore, every \mathbb{W}_0 -locally constant presheaf on it is weakly equivalent to a constant presheaf. \square

From general properties of localisation we get

Proposition 12.2.2. (1) *The Quillen adjunction $\text{sym}_n : \text{Op}_n(\mathbb{V}) \rightarrow \text{SOp}(\mathbb{V})$: des_n is factorisable through \mathbb{W}_k -local model structure for $k \geq 1$:*

$$\begin{array}{ccc} \text{Op}_n(\mathbb{V}) & \begin{array}{c} \xleftarrow{\text{des}_n} \\ \xrightarrow{\text{sym}_n} \end{array} & \text{SOp}(\mathbb{V}) \\ & \begin{array}{c} \searrow \text{id} \\ \swarrow \text{id} \end{array} & \begin{array}{c} \swarrow \text{des}_n \\ \searrow \text{sym}_n \end{array} \\ & & \text{Op}_n^{\mathbb{W}_k}(\mathbb{V}) \end{array}$$

- (2) *The following square is a square of Quillen adjunctions for $k \geq 1$:*

$$(12.2.1) \quad \begin{array}{ccc} \text{Op}_n^{\mathbb{W}_k}(\mathbb{V}) & \begin{array}{c} \xrightarrow{\text{sym}_n} \\ \xleftarrow{\perp} \\ \xleftarrow{\text{des}_n} \end{array} & \text{SO}(\mathbb{V}) \\ \begin{array}{c} \uparrow F_n \\ \downarrow U_n \end{array} \lrcorner & & \begin{array}{c} \uparrow F \\ \downarrow U \end{array} \lrcorner \\ [\mathbb{Q}_n^{op}, \mathbb{V}]^{\mathbb{W}_k} & \begin{array}{c} \xrightarrow{[-]_!} \\ \xleftarrow{\perp} \\ \xleftarrow{[-]^*} \end{array} & [\mathbb{S}^{op}, \mathbb{V}] \end{array}$$

- (3) *For $n = 2$ there are similar statements when we again replace symmetric groups on braid groups, symmetric operads on braided operads and corresponding symmetrisations.*

We now have the following refinement of Theorem 12.1.2.

Theorem 12.2.3. *Let \mathbb{V} be symmetric monoidal combinatorial model category with cofibrant tensor unit. Then:*

- (1) *The braided symmetrisation*

$$\text{bsym}_2 : \text{Op}_2^{\mathbb{W}_\infty}(\mathbb{V}) \rightarrow \text{BO}(\mathbb{V})$$

is a left Quillen equivalence;

(2) *Similarly the symmetrisation*

$$\text{sym}_\infty : \text{Op}_\infty^{\text{W}\infty}(\mathbb{V}) \rightarrow \text{SO}(\mathbb{V})$$

is a left Quillen equivalence.

Proof. This follows from Propositions 12.2.1, 12.2.2 and Theorem 12.1.2. \square

Remark 12.2.4. In the next two sections we will give a proof of a generalisation of this theorem independent of Theorem 12.1.2.

13. LOCALISABILITY OF SUBSTITUTES FOR OPERADS

The purpose of this section is to establish the following theorem:

Theorem 13.0.1. *The substitutes $(O^{(n)}, Q^{op})$, (BO, Br^{op}) and (SO, S^{op}) are left localisable.*

The proofs of localisability of these substitutes are very similar to each other. We provide a detailed proof for the case of the substitute $(NO^{(n)}, Q_n^{op})$ whose algebras are normalised n -operads. We then explain the changes necessary for this proof to work for general n -operads. The proofs for (BO, Br^{op}) and (SO, S^{op}) are, in fact, simpler and we leave them as an exercise for the reader. But we first need some preparation.

13.1. Polynomial monad for n -operads. A detailed description of polynomial monad $\mathcal{NO}^{(n)}$ can be found in [BB17, Section 12] but we do need to remind the reader of some points from there. We also discuss how to identify the underlying category of this monad with Q_n^{op} .

An n -ordered set is a set X with a given n -tuple $(<_0, \dots, <_{n-1})$ of complementary orders, meaning that any $x, y \in X$ can be compared with respect to exactly one of the orderings $<_0, \dots, <_{n-1}$ [Bat07, Definition 2.3]. An n -ordered set is *totally n -ordered* if $i <_p j$ and $j <_r k$ implies $i <_{\min(p,r)} k$ [Bat07, Definition 2.4].

A structure of a totally n -ordered set on X induces the following linear order $<_X$ on X called the total order: $i <_X j$ if and only if there exists $0 \leq p \leq n-1$ such that $i <_p j$. Given two n -ordered sets, X and Y , we say X *dominates* Y if $i <_p j$ in X implies either $i <_r j$ in Y for some $r \geq p$ or $j <_r i$ in Y for some $r > p$ [Bat07, Definition 2.6]. Let $J_n(k)$ denote the poset of total complementary n -orders on $\{1, \dots, k\}$ with respect to the domination relation.

We can now describe the set of operations of $\mathcal{NO}^{(n)}$ in terms of n -planar trees [BB17]. Let S be an n -ordinal and $Trees_S^{n,k}$ denote the set of labeled and decorated planar trees with k vertices called reduced n -planar trees [BB17] which we recall in the next paragraph.

An n -planar tree consists of a planar τ with k vertices equipped with:

- a structure of a totally n -ordered set T_v (decoration) on the set of incoming edges of every vertex v such that the total linear order generated by T_v coincides with the order coming from the planar structure of τ ;
- a labeling of the set of its leaves that is a bijection $\rho_\tau : |S| \rightarrow L(\tau)$ between the set of leaves of τ and the set $|S|$.
- a linear order on the set of vertices of τ .

An n -planar tree is *reduced* if each vertex has at least two incoming edges,

According to [Bat07] any n -planar tree τ determines an n -complementary relation on the set $|S|$ in the following way. Let w be a vertex or a leaf of τ and v be

a vertex of τ . We will say that w is *above* v if there exists a path in τ from w to v which does not contain two consecutive input edges of the same vertex. For any two leaves or vertices there exists a unique vertex $v(k, l)$ that is below k, l and such that any other vertex below to k and l is below v .

An n -complementary relation $\tau(S)$ on $|S|$ generated by τ is constructed as follows. For $p, q \in |S|$ let k, l be the corresponding leaves on τ (using ρ_τ). Let e_p be the input edge in $v(k, l)$, i.e. the last edge in the path from k to $v(k, l)$. Analogously let e_q be the input edge in $v(k, l)$ which is the last edge in the path from l to $v(k, l)$. Let $T(k, l)$ be the n -ordinal decorating $v(k, l)$. By definition, $p <_r q$ in $\tau(S)$ if $e_p <_r e_l$ in $T(k, l)$.

A reduced n -planar tree τ belongs to $Trees_S^{n,k}$ if it satisfies the following condition:

- (Δ) S dominates the complementary relation $\tau(S)$.

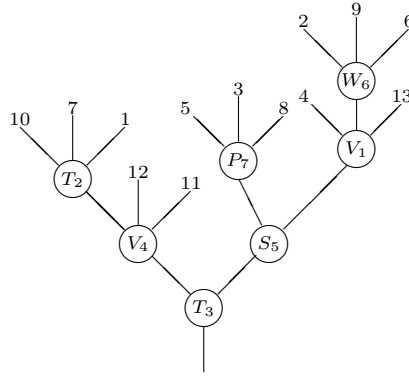

FIGURE 1. Typical reduced n -planar tree with seven vertices. Here V, W, P, T, S are n -ordinals decorating corresponding vertices and the subscripts indicate the linear order. The numbers on the leaves fix a bijection ρ_τ .

The coloured operad $\mathcal{NO}^{(n)}$ has nonempty and nonterminal n -ordinals as objects. For any list of n -ordinals $T_1, \dots, T_k; S$ the set of operations $\mathcal{NO}^{(n)}(T_1, \dots, T_k; S)$ is the subset of $Trees_S^{n,k}$ which consists of n -planar trees with decorations exactly T_1, \dots, T_k whose linear order coincides with the ordering of the list T_1, \dots, T_k . The symmetric group acts by changing the linear order (but does not change the tree structure). We will denote by $\tau_{\rho_\tau}(T_1, \dots, T_k; S) \in Trees_S^{n,k}$ a typical element from $\mathcal{NO}^{(n)}(T_1, \dots, T_k; S)$. One can take the value of the bimodule $d(\mathcal{NO}^{(n)})(T_1, \dots, T_k; S)$ equal to the set of $\tau_{\rho_\tau}(T_1, \dots, T_k; S)$ for which the linear order on vertices of τ coincides with the order generated by walking around τ in the clockwise direction.

Lemma 13.1.1. *The underlying categories of operads $O^{(n)}, \mathcal{CFO}^{(n)}$ and $\mathcal{NO}^{(n)}$ are the opposite to the category of quasibijections, the category of quasibijections between nonempty n -ordinals and the category of quasibijections between nonempty and nonterminal n -ordinals correspondingly.*

Proof. The proof is the same for all three operads above. We need to calculate $O^{(n)}(T; S)$. The underlying planar tree for a typical element from $O^{(n)}(T; S)$ must

be a corolla. The condition that S dominates the complementary relations generated by T is equivalent to the requirement that ρ_τ is a quasibijection. Hence, we have a bijection $O^{(n)}(T; S) \rightarrow Q_n(S, T)$. This bijection obviously takes the substitution operation in $O^{(n)}$ to the composition of quasibijections. \square

13.2. The bimodules $d(NO^{(n)})$ and $d(O^{(n)})$ are constantly disconnected. For the first point observe that the fiber $(T_1, \dots, T_k)/p'$ of the functor

$$p' : \int d(NO^{(n)}) \rightarrow (Q_n^{op})^k,$$

for a fixed list of n -ordinals T_1, \dots, T_k , has the following explicit description.

An object of this fiber is given by an element $\tau_{\rho_\tau}(T_1, \dots, T_k; S)$. A morphism in the fiber $(T_1, \dots, T_k)/p'$ from $\tau_{\rho_\tau}(T_1, \dots, T_k; S)$ to $\tau_{\rho_{\tau'}}(T_1, \dots, T_k; S')$ exists only if $\tau = \tau'$ and is determined by a quasibijection $\rho : S' \rightarrow S$ such that $\rho'_\tau = \rho_\tau \cdot |\rho|$.

It is obvious from this description that the fiber $(T_1, \dots, T_k)/p'$ splits as a coproduct of categories of the form

$$\coprod_{\tau} \tau(T_1, \dots, T_k)/p',$$

where the objects of the category $\tau(T_1, \dots, T_k)/p'$ are elements $\tau_{\rho_\tau}(T_1, \dots, T_k, S)$ with fixed planar tree τ .

Let $\mathcal{SO}^{NO^{(n)}}$ be the classifier for internal normal n -operads in a categorical symmetric operad (it was denoted \mathbf{rh}^n in [Bat07]).

Lemma 13.2.1. *The category $\tau(T_1, \dots, T_k)/p'$ is isomorphic to the comma-category $\tau/(J_n(k))^{op}$ from [Bat07, Lemma 4.2] if τ is considered as an object of $\mathcal{SO}^{NO^{(n)}}$. The categories $\tau/(J_n(k))^{op}$ and $\tau(T_1, \dots, T_k)/p'$ are finite posets with an initial object.*

Proof. Any element $\tau_{\rho_\tau}(T_1, \dots, T_k, S)$ is identified with an object of $(J_n(k))^{op}$ under τ because ρ_τ^{-1} provides a labeling of the elements of $|S|$ (that is, an object of $(J_n(k))^{op}$) and under this relabeling there is a unique morphism in $\mathcal{SO}^{NO^{(n)}}$ from τ to this object. It is clear that both categories are finite posets and that the correspondence above establishes an isomorphism of these posets.

Now we invoke Lemma 4.3 from [Bat07] which claims that the category $\tau/(J_n(k))^{op}$ is nonempty and connected. In fact the proof established more. Namely, that for each objects S' and S'' in this category there exists an object S and a span of morphisms $S' \leftarrow S \rightarrow S''$. Since the category is a directed and finite poset an obvious induction implies that $\tau/(J_n(k))^{op}$ has an initial object. \square

We can now finish the proof that the bimodules $d(NO^{(n)})$ and $d(O^{(n)})$ are constantly disconnected. We have to check that every k -tuple of quasibijections $f_1 : T_1 \rightarrow T'_1, \dots, f_k : T_k \rightarrow T'_k$ induces a weak equivalence of nerves of categories $(T_1, \dots, T_k)/p'$ and $(T'_1, \dots, T'_k)/p'$. But these categories are coproducts of categories over the same indexed set and the k -tuple f_1, \dots, f_k sends a summand indexed by τ to the summand indexed by τ . Since each summand has contractible nerve, we conclude that $N((T_1, \dots, T_k)/p') \rightarrow N((T'_1, \dots, T'_k)/p')$ is a weak equivalence and hence the substitute $(\mathcal{NO}^{(n)}, Q_n^{op})$ is left localisable.

The proof for the substitute $(O^{(n)}, Q_n^{op})$ is similar once we know that the analogue of Lemma 13.2.1 holds for these operads. Let $\mathcal{SO}^{O^{(n)}}$ be the classifier for

internal n -operads inside categorical symmetric operads (this is \mathbf{ph}^n from [Bat07]). It was shown in [Bat07, Lemma 8.2] that the natural operadic functor $p : SO^{O^{(n)}} \rightarrow SO^{NO^{(n)}}$ has a (nonoperadic) right adjoint which is the identity on the objects of $(J_n(k))^{op}$. This induces an adjoint pair of functors between $\tau/(J_n(k))^{op}$ and $p(\tau)/(J_n(k))^{op}$, so the nerve of $\tau/(J_n(k))^{op}$ is contractible again. The rest of the proof follows the same argument.

13.3. $(NO^{(n)}, Q_n^{op})$ and $(O^{(n)}, Q_n^{op})$ are unary tame. We check unary tameness of $(O^{(n)}, Q_n^{op})$ using the techniques from [BB17, Section 12.22]. The proofs for the other substitutes are very similar and simpler.

The classifier $(O^n)^{O^n + Q_n^{op}}$ has as objects n -planar trees with additional decoration of each vertex by colours X and K exactly like it was stated in [BB17, Section 12.26]. Similarly, the morphisms are generated by contractions of n -planar subtrees all whose vertices have X -color but we have additional generators which correspond to the action of quasibijections on vertices with colour K . Observe that these are unary morphisms which do not change the underlying planar tree.

The classifier $(O^n)^{Q_n^{op} + Q_n^{op}}$ has the same objects again but morphisms are generated by action of quasibijections only. We need to find a subcategory of $(O^n)^{Q_n^{op} + Q_n^{op}}$ which will be final in $(O^n)^{O^n + Q_n^{op}}$.

Let us call an object $a \in (O^n)^{O^n + Q_n^{op}}$ *noncontractible* if for any morphism $\phi : a \rightarrow b$ it is either a unary or a nullary morphism. If moreover, for any nullary $\phi : a \rightarrow b$ there is a morphism $\psi : b \rightarrow a$ such that $\psi \cdot \phi$ is the identity on a we call a a *noncontractible retract*. Recall that nullary generators are exactly the morphisms of inserting an X -vertex of valency two inside an edge of the n -planar tree. The last condition of retractability simply means that any insertion of a new X -vertex of valency two creates an internal edge connecting two X -vertices (we can then contract the subtree consisting of these two vertices) or, equivalently, there are no two K -vertices connected by an edge.

Let $\mathbf{nr} \subset (O^n)^{Q_n^{op} + Q_n^{op}}$ be the full subcategory of noncontractible retracts. Let us prove that it is final in $(O^n)^{O^n + Q_n^{op}}$.

We first need to show that for each $a \in (O^n)^{O^n + Q_n^{op}}$ there is at least one arrow to a noncontractible retract. Let $v(b)$ be the number of edges of the underlying planar tree of a . Notice that an object b is noncontractible if and only if for any morphism $\phi : b \rightarrow c$ the number $v(c) \geq v(b)$ and, hence, b is noncontractible if and only if $l(b) = v(b) - \min_{b \rightarrow c} v(c) = 0$. We now can use obvious induction by $l(a)$ to prove that there is a morphism $f : a \rightarrow b$ to a noncontractible object. Now, if b is noncontractible there is a unique way to map it to a noncontractible retract by inserting of an X -vertex to each edge connecting two K -vertices.

A further property of noncontractible retracts is: for any unary $\phi : a \rightarrow b$ if a is a noncontractible retract then b is a noncontractible retract as well. Indeed, if there exists $\psi : b \rightarrow c$ with $v(c) < v(b)$ then the composite $\phi \cdot \psi$ provides a morphism with $v(a) < v(c)$. Hence, b is noncontractible. It is also a noncontractible retract because a unary ϕ does not force two K -vertices become connected by an edge in b .

The category $(O^n)^{O^n + Q_n^{op}}$ has the following diamond property. Any span of generators

$$b \xleftarrow{\phi} a \xrightarrow{\psi} c$$

in C can be completed to a commutative square by a cospan of generators (or identities)

$$d \xrightarrow{\psi^*} d \xleftarrow{\phi^*} c.$$

The proof of this fact is exactly the same as in [BB17, Section 12.24].

Now, suppose we are given a span of generators $b \xleftarrow{\phi} a \xrightarrow{\psi} c$, where c is a noncontractible retract. Then we claim that we can complete this span to a commutative square in such a way that in the cospan $d \xrightarrow{\psi^*} d \xleftarrow{\phi^*} c$ the morphism ϕ^* is unary and d is a noncontractible retract. Indeed, since c is a noncontractible retract ϕ^* is either unary and everything is proved or nullary. If it is nullary there is a retraction $r : d \rightarrow c$ and postcomposing this cospan with r we get another cospan in which the right morphism is the identity.

Finally given a span of morphisms $b \xleftarrow{\phi} a \xrightarrow{\psi} c$ in which b and c both are noncontractible retracts we first factorise ϕ and ψ on generators and then complete the resulting diagram to a commutative grid using diamond property. Then we see from the previous argument that we always can obtain the grid such that in the chain of morphisms on the boundary

$$b \rightarrow d_1 \rightarrow \dots \rightarrow d_i \leftarrow e_j \dots \leftarrow e_1 \leftarrow c$$

all morphisms are unary and all objects are noncontractible retracts. Thus we proved that the category $a/(O^n)^{O^n + \mathcal{Q}_n^{op}}$ is connected and so $\mathbf{nr} \subset (O^n)^{O^n + \mathcal{Q}_n^{op}}$ is final.

Proof of Theorem 13.0.1. We finally use the criteria established in Theorem 10.2.6 and the results of Sections 13.2 and 13.3. □

14. STABILISATION OF OPERADS AND ALGEBRAS

In this Section we obtain an extension of Theorem 12.2.3 to all intermediate cases $2 < n < \infty$. It justifies our assertion that \mathbb{W}_∞ -locally constant n -operads are indeed a model of higher braided operads. We then apply it to prove a stabisation theorem for algebras.

14.1. Stabilisation of higher braided operads. For an n -ordinal R and $0 \leq p \leq n$ we consider its p -suspension $\mathbf{s}_p(R)$ which is an $(n + 1)$ -ordinal with the underlying set R , and the m -th order coincides with $<_m$ on R until $m < p$, the p -th order is empty and the m -th order for $m > p$ coincides with $<_{m-1}$ on R .

For example, the suspensions $\mathbf{s}_0(T)$ and $\mathbf{s}_2(T)$ of the 2-ordinal on the left are 3-ordinals displayed on the right:

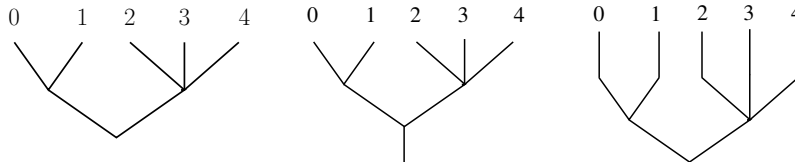

Suspension operations give us a family of functors

$$\mathbf{s}_p : Ord(n) \rightarrow Ord(n + 1), \quad 0 \leq p \leq n.$$

We also define an ∞ -vertical suspension functor $Ord(n) \rightarrow Ord(\infty)$ as follows. For an n -ordinal T its ∞ -suspension is an ∞ -ordinal $\mathbf{s}_\infty T$ whose underlying set is the

same as the underlying set of T and $a <_p b$ in $\mathbf{s}^\infty T$ if $a <_{n+p-1} b$ in T . It is not hard to see that the sequence

$$Ord(0) \xrightarrow{\mathbf{s}} Ord(1) \xrightarrow{\mathbf{s}} Ord(2) \longrightarrow \dots \xrightarrow{\mathbf{s}} Ord(n) \longrightarrow \dots \xrightarrow{\mathbf{s}^\infty} Ord(\infty),$$

exhibits $Ord(\infty)$ as a colimit of $Ord(n)$.

Any of the suspension functors can be restricted to the category of quasibijections. We will denote such a restriction by

$$\mathbf{s}_p : \mathbb{Q}_n \rightarrow \mathbb{Q}_{n+1}.$$

To simplify notation we will denote any suspension functor just \mathbf{s} since the results below are valid for any $0 \leq p \leq n$.

The suspension functor can be extended to a substitute morphism (cf. [Bat17] for explanation)

$$(O^{(n)}, \mathbb{Q}_n^{op}) \rightarrow (O^{(n+1)}, \mathbb{Q}_{n+1}^{op})$$

and in the limiting case to a morphism

$$(O^{(n)}, \mathbb{Q}_n^{op}) \rightarrow (O^{(\infty)}, \mathbb{Q}_\infty^{op}).$$

Both these morphisms are over the substitute of symmetric operads (SO, S) . Both morphisms will be denoted $(\Sigma, \mathbf{s}^{op})$ to shorten notations, moreover the same notations will be applied for any finite sequence of iterated suspensions:

$$(\Sigma, \mathbf{s}^{op}) : (O^{(n)}, \mathbb{Q}_n^{op}) \rightarrow (O^{(m)}, \mathbb{Q}_m^{op}), \quad n < m.$$

Proposition 14.1.1. *For any $n < m \leq \infty$ the morphism $(\Sigma, \mathbf{s}^{op})$ is Beck-Chevalley.*

Proof. It follows straightaway from Propositions 11.3.2 and 8.5.4. \square

We finally arrive to the following Stabilisation Theorem for higher operads.

Theorem 14.1.2. *Let \mathbb{V} be a combinatorial symmetric monoidal model category with the cofibrant tensor unit. Then for all $n \geq 3$ and $2 \leq k+1 \leq n$ the symmetrisation functor*

$$sym_n : Op_n^{\mathbb{W}^k}(\mathbb{V}) \rightarrow SO(\mathbb{V})$$

and the suspension functor

$$\Sigma_! : Op_n^{\mathbb{W}^k}(\mathbb{V}) \rightarrow Op_m^{\mathbb{W}^k}(\mathbb{V}), \quad n < m \leq \infty$$

are left Quillen equivalences.

For $n = 2$ and any $1 \leq k \leq \infty$ the functor

$$bsym_2 : Op_2^{\mathbb{W}^k}(\mathbb{V}) \rightarrow BO(\mathbb{V})$$

is a left Quillen equivalence.

Proof. The statements follow from points (4) and (5) of the Theorem 11.1.5, Theorem 13.0.1, Propositions 14.1.1 and 11.3.2 and Corollaries 10.2.4 and 4.2.3. \square

In the truncated case we obtain the following

Corollary 14.1.3. *Let $k \geq 0$ and let \mathbb{V} be a k -truncated combinatorial symmetric monoidal model category with the cofibrant unit. Then the symmetrisation functor*

$$sym_n : Op_n^{\mathbb{W}^\infty}(\mathbb{V}) \rightarrow SO(\mathbb{V})$$

and the suspension functor

$$\Sigma_! : Op_n^\infty(\mathbb{V}) \rightarrow Op_m^\infty(\mathbb{V}), \quad n < m \leq \infty$$

are left Quillen equivalences for $3 \leq k + 2 \leq n \leq \infty$.

For $n = 2$ and $0 \leq k \leq \infty$ the functor

$$bsym_2 : Op_2^{\mathbb{W}\infty}(\mathbb{V}) \rightarrow BO(\mathbb{V})$$

is a left Quillen equivalence.

Proof. It follows from Theorem 9.4.2. □

14.2. Baez-Dolan stabilisation. We now show how the Theorem 14.1.3 implies a version of the Baez-Dolan stabilisation hypothesis.

Following [Bat17] we give the following definitions. Let $Ass_n \in Op_n(\mathbb{V})$ be the operad with constant values $(Ass_n)_T = I$, $T \in Ord(n)$. Let $\mathcal{G}_n \in Op_n(\mathbb{V})$ be its cofibrant replacement. We will denote by $B_n(\mathbb{V})$ the category of \mathcal{G}_n -algebras in \mathbb{V} . Let also $E_\infty(\mathbb{V})$ be the model category of E_∞ -algebras in \mathbb{V} , that is, the category of algebras of a cofibrant replacement E of the symmetric operad Com .

There is an isomorphism of categories of algebras of an n -operad \mathcal{G}_n and an $(n + 1)$ -operad $\Sigma_!(\mathcal{G}_n)$ [Bat17, Lemma 2.5]. Since $\Sigma_!$ is a left Quillen functor, the operad $\Sigma_!(\mathcal{G}_n)$ is cofibrant. There is a map of $(n + 1)$ -operads $i : \Sigma_!(\mathcal{G}_n) \rightarrow \mathcal{G}_{n+1}$. Indeed, we have $\Sigma^*(Ass_{n+1}) = Ass_n$ and by adjunction we have a map $\Sigma_!(\mathcal{G}_n) \rightarrow Ass_{n+1}$. We also have a trivial fibration $\mathcal{G}_{n+1} \rightarrow Ass_{n+1}$. Since $\Sigma_!(\mathcal{G}_n)$ is cofibrant there is a lifting $i : \Sigma_!(\mathcal{G}_n) \rightarrow \mathcal{G}_{n+1}$.

The morphism i induces a Quillen adjunction between algebras of $\Sigma_!(\mathcal{G}_n)$ and algebras of \mathcal{G}_{n+1} and so between algebras of \mathcal{G}_n and \mathcal{G}_{n+1} . Slightly abusing notation we will denote this adjunction $i^* \vdash i_!$.

We also have maps $j_n : sym_n(\mathcal{G}_n) \rightarrow E$ for each $n \geq 2$ which induce Quillen adjunctions $j_n^* \vdash (j_n)_!$ between $B_n(\mathbb{V})$ and $E_\infty(\mathbb{V})$ which commute with i^* and $i_!$ [Bat17, Section 3.5].

Theorem 14.2.1. *Let $k \geq 0$ and let \mathbb{V} be a k -truncated combinatorial symmetric monoidal model category with the cofibrant tensor unit. Then*

$$i_! : B_n(\mathbb{V}) \rightarrow B_{n+1}(\mathbb{V})$$

and

$$(j_n)_! : B_n(\mathbb{V}) \rightarrow E_\infty(\mathbb{V})$$

are left Quillen equivalences for $n \geq k + 2$.

Proof. Let $n \geq 3$. The operad \mathcal{G}_n is cofibrant and is equipped with a trivial fibration to Ass_n . Applying sym_n to this trivial fibration we obtain $sym_n(\mathcal{G}_n) \rightarrow sym_n(Ass_n) = Com$. Let $Com \rightarrow Com'$ be a fibrant replacement in $SO(\mathbb{V})$. Then we have a map $sym_n(\mathcal{G}_n) \rightarrow Com'$. This induces a mate $\mathcal{G}_n \rightarrow des_n(Com')$. The functor des_n preserves weak equivalence between operads and so $des_n(Com')$ is weakly equivalent to $des_n(Com) = Ass_n$. So $\mathcal{G}_n \rightarrow des_n(Com)'$ is a weak equivalence because \mathcal{G}_n is a cofibrant replacement of Ass_n . Finally, since by the Theorem 14.1.3 sym_n is a left Quillen equivalence, the mate $sym_n(\mathcal{G}_n) \rightarrow Com'$ is a weak equivalence, and, hence, $sym_n(\mathcal{G}_n)$ is weakly equivalent to the E_∞ operad E . This proves the second statement.

The statement for $i_!$ follows again from the two out of three property.

The case $k = 0$ and $n = 2$ is somewhat special. But in this case the contractible 2-operad \mathcal{G}_2 gives a contractible braided operad $X = bsym_2(\mathcal{G}_2)$ by Theorem 14.1.3 after symmetrisation. Since \mathbb{V} is 0-truncated, the mapping space $Map_{\mathbb{V}}(X_n, X_n)$

is contractible, hence the action of the braid groups Br_n on X_n is homotopically trivial. □

Remark 14.2.2. Theorem 14.2.1 is an improvement of main result [Bat17, Theorem 3.7] where the existence of a standard system of simplices is required. On the other hand this Theorem from loc. cit. is proved for an arbitrary cofibrantly generated monoidal model category with cofibrant unit \mathbb{V} but Theorem 14.2.1 asks \mathbb{V} to be combinatorial.

Recall that Rezk’s $(n+k, n)$ -categories are fibrant objects in the model category $\Theta_n \text{Sp}_k$, $-2 \leq k \leq \infty$ which is a truncation of the model category of Rezk’s complete Θ_n -spaces $\Theta_n \text{Sp}_\infty$. The category $\Theta_n \text{Sp}_\infty$ is itself a certain Bousfield localisation of the category of simplicial presheaves $\text{Sp}^{\Theta_n^{op}}$ with its injective model structure. This is a cartesian closed combinatorial model category which is $(n+k)$ -truncated and satisfies all the hypotheses of Theorem 14.2.1 (see [Rez10]). Recall also that the category of Rezk’s m -tuply monoidal $(n+k, n)$ -categories is the category of fibrant objects in the (semi)model category $B_m(\Theta_n \text{Sp}_k)$.

We immediately have

Corollary 14.2.3 (Stabilisation for Rezk’s $(n+k, n)$ -categories). *The suspension functor induces the left Quillen equivalence*

$$i_! : B_m(\Theta_n \text{Sp}_k) \rightarrow B_{m+1}(\Theta_n \text{Sp}_k)$$

for $m \geq n+k+2$ and, hence, an equivalence between homotopy categories of Rezk’s m -tuply monoidal $(n+k, n)$ -categories and Rezk’s $(m+1)$ -tuply monoidal $(n+k, n)$ -categories.

Remark 14.2.4. The category of Rezk’s complete Θ_n spaces is the only known model of higher categories equipped with a monoidal model structure. Conjecturally, other model of higher categories such that Tamsamani, Segal, or quasi n -categories can be equipped with such a tensor product (higher analogues of the Gray tensor product of 2-categories) but we are not aware about any complete work in this direction. If this structure appears in the future, our methods should immediately provide the Baez-Dolan stabilisation theorem for the corresponding model.

Acknowledgements. We wish to express our gratitude to C.Berger, R.Garner, E.Getzler, A.Joyal, S.Lack, M.Markl, R.Street, M.Weber for many useful discussions.

The first author is especially grateful to Denis-Charles Cisinski. Most ideas regarding locally constant presheaves belong to him. This paper would never be written without our long conversations and his illuminating explanations. The first author also gratefully acknowledges the financial support and inspiring working atmosphere of Max Plank Institut für Mathematik, where a substantial part of the paper was written during his 2016 visit, and Institut des Hautes Étude Scientifiques in Paris, where the paper was finished in January 2020.

The second author gratefully acknowledges the support of the National Science Foundation under Grant No. IIA-1414942, the Australian Academy of Science, and the Australian Category Theory Seminar. He is grateful to Macquarie University for hosting him on three occasions while we carried out this research.

BIBLIOGRAPHY.

- [BD95] Baez J., Dolan J., Higher-dimensional algebra and topological quantum field theory, *Journal Math. Phys.* **36** (1995), 6073-6105. [46](#)
- [Bar10] Barwick, C., On left and right model categories and left and right Bousfield localizations. *Homology, Homotopy Appl.*, 12(2):245–320, 2010. [4](#), [6](#), [42](#)
- [BBPTY16a] Maria Basterra, Irina Bobkova, Kate Ponto, Ulrike Tillmann, Sarah Yeakel. Inverting operations in operads. *Topology and its Applications*, 235 (2017), 130-145. Available as arXiv:1611.00715, 2016. [3](#)
- [Bat07] Batanin M.A., *The symmetrisation of n -operads and compactification of real configuration spaces*, Adv. Math. **211** (2007), pp. 684-725. [3](#), [16](#), [46](#), [47](#), [48](#), [50](#), [53](#), [55](#), [56](#)
- [Bat08] Batanin M.A., *The Eckmann-Hilton argument and higher operads*, Adv. Math. **217**(2008), pp. 334-385. [3](#), [4](#), [16](#), [17](#), [46](#), [49](#)
- [Bat10] Batanin M.A., *Locally constant n -operads as higher braided operads*, J. of Noncommutative Geometry 4 (2010), 237-265. [46](#), [47](#), [51](#)
- [Bat17] Michael Batanin. An operadic proof of the Baez-Dolan stabilisation hypothesis, *Proceedings of the AMS* 145, 2785-2798, 2017. [46](#), [50](#), [58](#), [59](#), [60](#)
- [BB17] Michael Batanin and Clemens Berger. Homotopy theory for algebras over polynomial monads, *Theory and Application of Categories*, Vol. 32, No. 6, 148-253, 2017. [1](#), [2](#), [3](#), [13](#), [16](#), [17](#), [18](#), [19](#), [20](#), [21](#), [22](#), [25](#), [27](#), [28](#), [29](#), [31](#), [49](#), [53](#), [56](#), [57](#)
- [BL17] Michael Batanin and Florian De Leger, *Polynomial monads and delooping of mapping spaces*, *J. Noncommut. Geom.*, Vol. 13 (2019), 1521-1576, arXiv:1712.00904. [3](#), [16](#), [18](#)
- [BKW18] Michael Batanin, Joachim Kock and Mark Weber, *Regular patterns, substitutes, Feynman categories and operads*, *Theory and Application of Categories*, vol. 33, 6-7, p.148-192, 2018. [3](#), [12](#)
- [BW15] Michael Batanin and David White. Baez-Dolan Stabilization via (Semi-)Model Categories of Operads, accepted to the *Proceedings of the Opening Perspectives in Algebra, Representations, and Topology (OP-ART) Conference at CRM, Barcelona*. 2015. [4](#)
- [BW16] M. Batanin and D. White, *Left Bousfield localization and Eilenberg-Moore Categories*, available as arXiv:1606.01537, 2016. [2](#), [9](#), [41](#)
- [BW20] M. Batanin and D. White, *Left Bousfield localization without left properness*, available as arXiv:2001.03764, 2020. [3](#), [7](#), [8](#)
- [BM03] Berger C., Moerdijk I., *Axiomatic homotopy theory of operads*, Comment. Math. Helv. 78 (2003), 805-831. [7](#)
- [Cis06] Cisinski D.C., *Les préfaisceaux comme modèles des types d'homotopie* (French, with English and French summaries), Astérisque 308, xxiv+390, 2006. [2](#), [33](#), [34](#), [35](#), [37](#), [38](#), [39](#)
- [Cis09] Cisinski D.C., *Locally constant functors*. Math. Proc. Camb. Phil. Soc., 147 (2009), 593-614. [2](#), [4](#), [34](#), [35](#), [36](#), [39](#), [43](#)
- [DS03a] Day B., Street R., Lax monoids, pseudo-operads, and convolution, in: "Diagrammatic Morphisms and Applications", *Contemporary Mathematics* 318 (2003) 75–96. [3](#), [12](#), [13](#), [15](#)
- [DS03b] Day B., Street R., Abstract substitution in enriched categories, *J. Pure Appl. Algebra* 179 (2003) 49–63. [3](#), [11](#), [12](#), [13](#), [15](#), [26](#)
- [Dug03] Dugger D., Replacing model categories by simplicial ones. *Transactions of the American Mathematical Society*, Volume 353, Number 12, Pages 5003-5027, 2003. [37](#)
- [DK80] Dwyer W., Kan D., Simplicial localization of categories, *Journal of pure and applied algebra* 17 (1980) 267-284 [40](#)
- [FGHW08] Fiore M., Gambino N., Hyland M., Winskel G., *The cartesian closed bicategory of generalised species of structures*, *Journal of the London Math Society*, Volume 77, Issue 1, 2008, Pages 203-220. [13](#)
- [Fre09] Fresse B., *Modules over operads and functors*, volume 1967 of *Lecture Notes in Mathematics*. Springer-Verlag, Berlin, 2009. [5](#), [6](#), [7](#)
- [Fre12] Fresse B., *Homotopy of Operads & Grothendieck-Teichmüller Groups*, Part 1 and 2, *Mathematical Surveys and Monographs*, AMS, volume 217; 2017. [2](#)
- [GK13] Gambino N., Kock J., *Polynomial functors and polynomial monads*, *Math. Proc. Cambridge Philos. Soc.* 154 (2013), no. 1, 153–192. [1](#)
- [Get10] Getzler E., *Operads Revisited*, *Algebra, Arithmetic and Geometry*, Progress in Mathematics, 269, Springer-Verlag 2010, 675-698. [3](#), [12](#)
- [Gui80] Guitart R., *Relations et carrés exacts*, *Ann. Sc. Math. Québec* **IV** (1980), 103–125. [19](#)

- [Hir03] Hirschhorn P., *Model categories and their localizations*, volume 99 of *Mathematical Surveys and Monographs*. American Mathematical Society, Providence, RI, 2003. [4](#), [7](#), [8](#), [9](#)
- [Hov99] Mark Hovey. *Model categories*, volume 63 of *Mathematical Surveys and Monographs*. American Mathematical Society, Providence, RI, 1999. [4](#), [6](#)
- [Kel74] Kelly G. M. On clubs and doctrines. In Category Seminar (Proc. Sem., Sydney, 1972/1973), pages 181-256. *Lecture Notes in Math.*, Vol. 420. Springer, Berlin, 1974. [13](#)
- [Lav97] T.G. Lavers. The theory of vines. *Communications in Algebra*, 25:1257–1284, 1997. [49](#)
- [Mal0] Malsiniotis G., *Carré exacts homotopiques, et dérivateurs*, *Cahiers de Top. et Géom. Diff. Catégoriques*, LIII, (1), 3-63, 2012. [9](#)
- [Mal05] Malsiniotis G., *La théorie de l'homotopie de Grothendieck*, *Astérisque*, vol. 301, Soc. Math. France, (2005). [2](#), [35](#)
- [MS04b] James McClure and Jeffrey Smith. Cosimplicial Objects and little n-cubes I. *Amer. J. Math.*, 126(5):1109-1153, 2004. [13](#)
- [McD79] McDuff D., On the classifying spaces of discrete monoids. *Topology*, Volume 18, Issue 4, 1979, Pages 313-320. [40](#)
- [Mur11] Muro F. Homotopy theory of nonsymmetric operads, *Algebr. Geom. Topol.* 11 (2011), no. 3, 1541-1599. [26](#)
- [Spi01] Spitzweck M., *Operads, Algebras and Modules in Model Categories and Motives*, PhD thesis, Bonn, 2001. Available electronically from <http://arxiv.org/abs/math/0101102>. [4](#), [6](#), [7](#)
- [SS00] Schwede S. and Shipley B.E., *Algebras and modules in monoidal model categories*. *Proc. London Math. Soc.*, 3, 2000. [3](#)
- [Rez10] Rezk C. A Cartesian presentation of weak n -categories, *Geom. Topol.* 14 (2010) 521-571. [60](#)
- [RSS01] Rezk C., Schwede S., Shipley S., Simplicial structures on model categories and functors, *American Journal of Mathematics*, 123(3), 551-575, 2001. [37](#)
- [Web16] Weber M., Algebraic Kan extensions along morphisms of internal algebra classifiers, *Tbilisi Mathematical Journal*, 9(1), (2016), pp. 65-142. [19](#), [20](#)
- [WY18] David White and Donald Yau. Bousfield localizations and algebras over colored operads, *Applied Categorical Structures*, 26:153-203, 2018. [6](#), [7](#), [45](#)
- [WY16] David White and Donald Yau, Homotopical adjoint lifting theorem, *Applied Categorical Structures*, 27:385-426, 2019 [41](#)

DEPARTMENT OF MATHEMATICS, MACQUARIE UNIVERSITY, NORTH RYDE, 2109 SYDNEY, AUSTRALIA

E-mail address: michael.batanin@mq.edu.au, bataninmichael@gmail.com

DEPARTMENT OF MATHEMATICS AND COMPUTER SCIENCE, DENISON UNIVERSITY, GRANVILLE, OH 43023

E-mail address: david.white@denison.edu